



Intensifying the grid:

*a typology for medium density housing to accommodate the changing
demography of Wellington suburbs.*

Rose Stiles

Submitted in partial fulfilment of the
Master of Architecture (Professional)
Degree 2012
Victoria University of Wellington, School of
Architecture

Rose Stiles

Abstract

The combination of an increasing population, changing demographics and an ageing housing stock is driving the need for new and more varied housing types. Attempts to address these concerns have been less than satisfactory, leading to urban sprawl and the destruction of neighbourhood character. Residential intensification is a way of providing new housing while preserving both Wellington's compact urban form and open space.

This thesis explores a process to increase housing density in the inner suburbs without a loss of urban form and character. Developed through design led research, the study first identifies those neighbourhoods most suited for intensification as Wellington's historic gridded suburbs. A representative street is then selected, and a strategy for integrating medium-density housing is developed. It then applies the principles in two multi-unit developments to address modern concerns with enhanced liveability and improved connection with private outdoor space.

By manipulating the buildings in plan and section, complex internal configurations are possible, resulting in different sizes and types of dwellings, which accommodates varied demographic groups and household sizes. Through the elevation, the designs are then integrated into the local character of the site by reinterpreting the street's context in a contemporary manner. The design resolution was reached through a cyclical process, developing and being tested incrementally.

The general principles of the design can be extrapolated and applied to other Wellington gridded neighbourhoods. They can also be applied to other locations with similar urban morphology in other New Zealand and Australian cities.

Acknowledgements

I would like to acknowledge my supervisors, Jacquie and Diane, for all their help, encouragement, and group get-togethers. Thanks to my fellow stream members for always being ready with advice and discussion, also to my class-mates for the endless tea breaks and distractions.

Thank you to my parents, Robyn and Clark, and my sister, Clover, for supporting me throughout my degree, and my grandfather, Roger, for five years worth of structural advice. Thanks also to mum and Andrew for their thorough proof-reading.

Table of contents

	Abstract	v
	Acknowledgements	vii
	Table of contents	ix
	List of figures	xi
	Introduction	1
Chapter one	Literature review	9
	Introduction	11
	Initial problem – increasing population, changing demographic make-up, housing obsolescence	12
	Potential solutions – increasing density of existing urban form	16
	Housing strategies	20
	Providing quality housing	22
	Providing diverse dwelling types for emerging demographic groups	23
	Integrating new development into built context	24
	Conclusions	27
Chapter two	Precedents review	29
	Introduction	31
	Responsive, adaptable housing – plan	31
	Internal configuration providing diverse dwelling types – section	36

	Integrating new development into historical fabric – elevation	42
	Conclusions	48
Chapter three	Design case-study	51
	Introduction	53
Part A	Site analysis	55
	Wellington – locating intensification	56
	Newtown	86
	The Street	90
	Victorian townhouse	96
Part B	Design	101
	Plan – responding to grid and sun orientation	107
	Section – providing diverse dwelling types and sizes	121
	Elevation – integrating into existing streetscape	126
Chapter four	Design discussion	157
	Assessment and evaluation of design solution	159
	Principles	162
	Aspects outside scope of thesis	163
Chapter five	Conclusion	165
	Bibliography	171
	Appendix A	180
	Appendix B	182
	Appendix C	184

List of figures

<i>Figure</i>	<i>Title</i>	
Chapter one		
Literature review		
1.1	Wellington projected population growth	12
1.2	Wellington current demographic household make-up	12
1.3	Wellington projected housing growth	13
1.4	Wellington projected dwelling type demand	13
1.5	Wellington current dwelling types	14
1.6	Houses in Seaside, Florida	24
1.7	House in Alcobaça, Topos Atelier de Arquitectura	24
1.8	1028 Natoma Street, San Francisco, Stanley Saitowitz	25
Chapter two		
Precedents review		
2.1	Adaptable House, two possible occupations	33
2.2	Dividable House, two possible occupations	33
2.3	Compact Courtyard House	34
2.4	Compact Courtyard House, designing for solar orientation	35
2.5	Compact Courtyard House, various plan arrangements	35
2.6	Compact Courtyard House, suburban intervention	35
2.7	VM Houses	38
2.8	VM Houses, Building M cross section	39
2.9	VM Houses, Building V cross section	39
2.10	Double House	40
2.11	Double House, section	41
2.12	Double House, sectional perspective	41
2.13	Double House, development diagram	41
2.14	Gore Street Housing, street perspective	45
2.15	Gore Street Housing elevation	45
2.16	Gore Street Housing, street perspective	45
2.17	Thin Flats, street perspective	47
2.18	Thin Flats, elevation	47

List of figures

<i>Figure</i>	<i>Title</i>	
2.19	Thin Flats, windows detail	47
Chapter three	Design case-study	
3.1	Plan of the town of Wellington, Port Nicholson, 14 August 1840	56
3.2	Plan of the city of Wellington and surrounding districts, 1880	57
3.3	Houses scattered amongst hills in Island Bay	58
3.4	Houses scattered amongst hills in Island Bay	58
3.5	Houses on gridded streets (mid-ground), houses dispersing into hills (back-ground)	58
3.6	Wellington, showing topography, suburbs, street network	58
3.7	Wellington, showing street network and suburbs for study	59
3.8	Residential population projected increase 2006-2030	60
3.9	Average household size 2006	61
3.10	Dwelling and inhabitant density 2006	61
3.11	Projected dwelling and inhabitant density 2030	62
3.12	Aerial view over Karori	62
3.13	Karori, suburb	66
3.14	Karori, block	67
3.15	Karori, houses	67
3.16	View over Island Bay	67
3.17	Island Bay, suburb	68
3.18	Island Bay, block	69
3.19	Island Bay, houses	69
3.20	View over Berhampore, looking towards Wellington Harbour	69
3.21	Berhampore, suburb	70
3.22	Berhampore, block	71
3.23	Berhampore, houses	71
3.24	Aerial view over Newtown	72
3.25	Newtown, suburb	73
3.26	Newtown, block	73
3.27	Newtown, houses	73
3.28	View over Lyall Bay	74
3.29	Lyall Bay, suburb	75

<i>Figure</i>	<i>Title</i>	
3.30	Lyall Bay, block	75
3.31	Lyall Bay, houses	75
3.32	View over Kilbirnie	76
3.33	Kilbirnie, suburb	77
3.34	Kilbirnie, block	77
3.35	Kilbirnie, houses	77
3.36	View over Miramar	78
3.37	Miramar, suburb	79
3.38	Miramar, block	79
3.39	Miramar, houses	79
3.40	Aerial view of Seatoun	80
3.41	Seatoun, suburb	81
3.42	Seatoun, block	81
3.43	Seatoun, houses	81
3.44	Suburbs compared (street network, street grid, block and subdivision, footprints, house placement)	83
3.45	Newtown, urban form and amenities	87
3.46	Detail showing Newtown, plan of the city of Wellington and surrounding districts, 1880	88
3.47	Detail showing Newtown. plan of the town of Wellington Port Nicholson, 14 August 1840	88
3.48	Urban grain sketch	89
3.49	Roy Street 1909	90
3.50	Roy Street circa 1920	90
3.51	Roy Street existing site plan	91
3.52	Roy Street house ages	92
3.53	Roy Street house storeys	92
3.54	Roy Street panorama	93
3.55	Roy Street trees	94
3.56	Town belt surrounding Roy Street	94
3.57	Roy Street trees and greenery	95

List of figures

<i>Figure</i>	<i>Title</i>	
3.58	Plan of five seven roomed houses, Roy Street, Newtown, for Messrs Crighton and Parke	96
3.59	Victorian townhouse plan and circulation	97
3.60	Figures- Victorian townhouse connection to outdoor space	97
3.61	Sunlight analysis: sketch of sunlight for plan when oriented north (left), and south (right)	99
3.62	Subdivision pattern before and after	103
3.63	Roy Street car parking plan	105
3.64	Roy Street proposed site plan	106
3.65	Spatial organisation for orientation to street and sun on north-facing site	108
3.66	Typical ground floor plan showing two units, small, large	109
3.67	Typical first floor plan showing two units, small, large	109
3.68	Typical second floor plan showing one unit, large	109
3.69	Typical living area of small unit	110
3.70	Typical terrace and courtyard area of large unit	110
3.71	Typical living and dining area of large unit, looking across terrace	111
3.72	Ground floor plan	112
3.73	First floor plan	113
3.74	Second floor plan	113
3.75	Spatial organisation for orientation to street and sun on south-facing site	114
3.76	Typical ground floor plan showing two units, large, small	115
3.77	Typical first floor plan showing two units, large, small	115
3.78	Typical second floor plan showing one unit, large	115
3.79	Typical dining room and deck in large unit	116
3.80	Typical ground floor and first floor deck in large unit	117

<i>Figure</i>	<i>Title</i>	
3.81	Ground floor plan	118
3.82	First floor plan	119
3.83	Second floor plan	119
3.84	Longitudinal sections	122
3.85	Cross section through one house (ground floor: hallway, first floor: bedrooms, stairs, second floor: living room, lightwell, kitchen)	123
3.86	Cross section through one house (ground floor: flexible room, laundry, bedroom, first floor: bedrooms and bathroom, second floor: living room, courtyard, dining room)	123
3.87	Cross section through two houses (small house: first floor: flexible room, hallway, bedroom, first floor: living and kitchen, large house: first floor: bedroom, second floor: terrace, dining room)	123
3.88	Longitudinal sections	124
3.89	Cross section through one house (ground floor: deck, living area, first floor: terrace, dining room, kitchen, second floor: bedrooms)	125
3.90	Cross section through two houses (ground floor: deck, living, dining, kitchen, first floor: bedrooms, second floor: bedrooms)	125
3.91	Five Victorian townhouses, built to same plan in 1906	126
3.92	Proportions diagram	127
3.93	Massing diagram	127
3.94	Fenestration diagram	128
3.95	Entrance diagram	128
3.96	Roofline diagram	129
3.97	Materials diagram	129
3.98	Articulation diagram	130
3.99	Colour diagram	130
3.100	Overall diagram	131
3.101	Proportions diagram - north-facing design	134

List of figures

<i>Figure</i>	<i>Title</i>	
3.102	Proportions diagram - south-facing design	135
3.103	Massing diagram - north-facing design	136
3.104	Three-dimensional massing diagram - north-facing design	136
3.105	Massing diagram - south-facing design	137
3.106	Three-dimensional massing diagram - south-facing design	137
3.107	Fenestration diagram - north-facing design	138
3.108	Fenestration - north-facing design	138
3.109	Fenestration diagram - south-facing design	139
3.110	Fenestration - south-facing design	139
3.111	Roofline diagram - north-facing design	140
3.112	Roofline diagram - south-facing design	141
3.113	Exterior cladding details - north-facing design	142
xvi 3.114	Exterior cladding details - south-facing design	143
3.115	Articulation diagram - north-facing design	144
3.116	Typical window - north-facing design	144
3.117	Articulation diagram - south-facing design	145
3.118	Typical window - south-facing design	145
3.119	Colour scheme - north-facing design	146
3.120	Colour scheme - south-facing design	146
3.121	Entrance – north-facing design	147
3.122	Entrance – south facing design	147
3.123	Front garden plan - south-facing design	148
3.124	Front garden plan - north-facing design	148
3.125	Front garden - north-facing design	149
3.126	Front garden - south-facing design	149
3.127	Street elevation in context - north-facing design	150

<i>Figure</i>	<i>Title</i>	
3.128	Street elevation in context - south-facing design	151
3.129	Street elevation - north-facing design	152
3.130	Street elevation - south-facing design	153
3.131	Street perspective - north-facing design	154
3.132	Street perspective - south-facing design	155
Design discussion		
4.1	Block redevelopment - incremental increase in density over time	159
4.2	Planning for sun orientation - South and east-facing sites, north and west-facing sites	162
4.3	Changing section providing different dwelling sizes	162
4.4	Architectural elements for reinterpretation and integration into existing context (proportions, massing, fenestration, roofline, materials, articulation, colour, entrance, ground treatment and planting)	163
Appendix A		
A.1	North-facing plan development	180
A.2	South-facing plan development	181
Appendix B		
B.1	Section development	182
B.2	North-facing section development	183
B.3	South-facing section development	183
Appendix C		
C.1	North-facing facade development - massing	184
C.2	South-facing facade development - massing	185
C.3	North-facing facade development - fenestration	186
C.4	South-facing facade development - fenestration	187
C.5	North-facing facade development - roofline	188
C.6	South-facing facade development - roofline	189
C.7	North-facing facade development - materials	190

Introduction

Defining the problem

Wellington's population is projected to grow by 17% between 2006 and 2026, while the number of dwellings is expected to grow by 28%. Shrinking household sizes is the main cause of this discrepancy. As demographic groups are changing, and the traditional family structure is declining, households are steadily becoming smaller. The most common emerging demographic groups are childless couples or single people living alone. There is a need to increase the range of dwelling types available in order to provide adequate choice for diverse households (Bunker and Gleeson et al 2002).

Thus the question becomes where and how to accommodate these people. Typical suburban subdivisions are appropriate for traditional family types but don't successfully accommodate emerging groups such as empty nesters, young professionals, single-parent families, and multi-generational families. Urban and environmental pressures are discouraging greenfield development, so the bulk of new housing must be accommodated within the existing city fabric.

Residential intensification, or the insertion of medium-density housing into existing suburbs, is recognised as an effective strategy to increase residential density, reduce the need for new infrastructure, optimise public transport use, and provide economic support to neighbourhood centres. However, there is often resident opposition to this form of development in their neighbourhoods. These oppositions arise from a perceived downgrading of local character through unsympathetic or out-of-scale developments (Weidinger 2010). Many built examples of medium-density housing in Wellington are poorly designed, do not integrate with the historical context, and have too high a density to suit the area.

There is a large body of literature relating to residential intensification and urban consolidation. Much of this literature is found in planning theory, which looks at the issues from a wider urban context. Current urban design theories incorporate the physical urban context from the scale of the city down to the individual street or building. Housing studies are used to compare the effectiveness of medium-density housing forms and typologies, and residents' experiences living in them. Writings on urban design and architecture consider people's perceptions of built form, and ways in which design can address the problem of integrating new development into an existing context. The literature provides a guide for understanding the position and scope of the research.

Therefore, the problem is: *how to design a medium-density housing typology that accommodates a wide range of demographic groups, in established suburbs that integrates with, or enhances, the local character of Wellington's older suburbs.*

Architecture's role

Architecture can be used to effectively engage the problem through a number of strategies:

- Urban design: identifying the optimum locations for intensification through analysis of the urban fabric.
- Planning: planning a range of dwelling types or sizes that have the inherent flexibility to accommodate different groups, and to adapt to changing needs over time. Organising programme and space efficiently, and in response to site conditions in order to enhance liveability.
- Design: using architectural tools such as massing, façade design and detailing to integrate a medium-density development into its context.

Architecture can be used to effect solutions for the broader social issues of demographic changes, as well as site-specific issues of context, scale and materials.

Research method

4

The research is undertaken in multiple overlapping phases. First, a literature review is undertaken to understand the scope of the issues; then a review of architectural precedents offers built solutions based on the common themes of the literature. The next step is to apply the solutions, both written and built, to a specific site, and to use architectural design to come to a unique resolution. The design is then evaluated in the light of the principles and ideas extracted from the reviews of literature and precedents.

A review of relevant literature, with a particular focus on New Zealand and Australian-based writing, provides a solid understanding of the issues. The literature surveyed incorporates a wide range of scales, from the city as a whole, to neighbourhoods, blocks, streets and individual buildings. Literature is chosen from a number of fields, including planning, urban design and environmental behaviour in order to understand the issues from several perspectives or ways of thinking. The best practice or most commonly advocated-for principles are identified.

Precedents are selected for analysis based on the way they offer solutions to the different problems raised in the literature review. The precedents are analysed first from a planning context – how they can accommodate different dwelling structures and changing lifestyles. Secondly, they are examined to understand how they respond to site conditions. Finally, they are explored from a design context – how they use architectural design to integrate with the fabric of their surroundings. Various strategies for dealing with the problems are then identified.

The knowledge gained from the literature review and precedent studies is then applied to a specific site in Wellington. The case-study section employs architectural design to incorporate the principles identified. The specific constraints of the site mean that the general principles have to be adapted, and multiple solutions explored for the issues of scale, planning, massing, and façade design. At each stage of development, the design is tested against the site context and the initial brief. The research through design process is incremental and evolutionary, relying on constant testing and reworking. The design solution is then evaluated against the findings from the review of literature and precedents, and new knowledge is assessed.

Research scope

The research is primarily focused on issues specific to the Wellington context as this is the chosen location for the design case-study. However, cities across New Zealand and Australia have much in common with the social make-up and physical structure of Wellington, therefore their lessons can be applied. The research is also specifically focused on medium-density housing, including such typologies as flats, townhouses and terrace housing, rather than high density apartments. Residential suburbs are focused on, while inner-city residential developments are excluded. This suburban focus is further narrowed down to established suburbs that have developed over time, rather than new, purpose-built subdivisions.

The research into demographic groups is kept general; rather than looking at specific solutions for particular groups, the aim is to develop more loose-fit solutions that can accommodate the widest range of dwelling structures.

Research significance

This research is significant because its findings can be applied beyond the case-study site. The design was developed with a wider application than the specific site in mind - the design outcomes can be applied to any of the gridded sites identified in the early stage of the case-study, or sites with a similar urban form in other cities. Not only can the specific plan be replicated in other sites, but general design principles provide a guide for adapting the building's appearance to integrate with its local context.

Many other cities in New Zealand and Australia are facing the same social and urban pressures as Wellington, and this research offers a new approach to implementing residential intensification as a way to accommodate a growing population while preserving urban form.

Outline of chapters

Chapter one: The literature review

This chapter summarises and compares the body of literature surrounding the topic of residential intensification. First, the initial problem of a growing population and increasing demographic groups is quantified. Next, urban theories that support high density urban development, such as Compact City, Smart Growth, urban consolidation, and Transit-Oriented Development, are compared and discussed. The focus then narrows to housing strategies, namely residential intensification and infill development. Planning and design of housing typologies that accommodate different demographic groups and have capacity to support changing dwelling structures are examined. Finally, issues of integrating new developments into a local context are explored.

Chapter two: The precedents review

This chapter examines built and unbuilt examples by architects who have dealt with various aspects of the issues identified in the literature review. First, designs that are adaptable or flexible, and responsive to site conditions, are examined for planning strategies that can support a range of demographic groups over time (plan). Next, buildings that have complex internal configurations of multiple dwelling units in order to provide a range of dwelling types are studied (section). Finally, medium-density developments in a suburban context are assessed for the way the design integrates into the existing streetscape (elevation). The lessons learnt from these three aspects are combined and applied to the case study design.

Chapter three: The case-study design

The case study takes the information from the literature review and precedents review and applies it to a specified site. In order to select a site a study of the suburbs in Wellington was undertaken. Then, an in-depth analysis of the development of the chosen site over time was undertaken, involving historical mapping, in order to understand the next iteration of development. The next step was to analyse the site's natural and built character. The street's main housing typology was examined closely. The design development began with plans responding to sun orientation. Then the building was manipulated in section in order to provide varying-sized dwellings. Finally the architectural elements of the typology were reinterpreted in order to integrate the new buildings into the existing streetscape.

Chapter four: Design discussion

Here the case-study design is assessed and evaluated against the initial problem and the

findings from the review of literature and precedents. Ways in which the design may adapt to future demographic changes are discussed, and general principles for layout and integration are extrapolated from the case-study design. Future morphological development is also explored

Chapter five: Conclusions

The findings from the research and design process are summarised and further research directions are identified and discussed.

Literature review

Introduction

This review of relevant literature seeks to form an understanding of the body of knowledge surrounding the topic of residential intensification.

The parameters applied to the literature selected were intended to keep the scope focused on suburban issues, therefore writings on inner city residential development were largely ignored, as the context of an inner city with its wide mix of uses and 24/7 activity cycle is markedly different to that of suburbia. Because Wellington's suburban tradition is mostly that of pre World War II and immediately post-War, research regarding modern subdivisions built along American principles is also irrelevant for the most part.

Most of the literature surveyed is taken from Australia and New Zealand, as the Australian suburban experience is somewhat similar to that of New Zealand. Both countries were colonised at the same time, and their urban forms have developed along similar principles. Both countries also have similar demographic and socio-economic make-up (bunker and Gleeson et al 2002). American literature was selectively used as their urban form issues are of a completely different scale to those of New Zealand. European literature was also used sparingly because the entrenched historical condition of medieval urban development is markedly different to New Zealand.

The literature review is structured with a wide focus, narrowing down to specific issues as the research progresses. The initial problem of how to house an increasing population and changing demographic groups is first defined, and then potential solutions are explored through urban theories that encourage higher residential densities such as urban growth boundaries, urban consolidation and compact city form. The next part of the research examines housing strategies that support the implementation of these urban theories. The issues inherent within higher density forms of housing are examined, including potential locations for intensive housing, and strategies for integrating it into an existing built context. The initial problem of housing increasingly varied demographic groups is then reconsidered in more detail by examining medium-density typologies and internal configurations that support diverse dwelling structures.

The overall aim of the research is to compare the various urban theories that call for higher density development and residential intensification. It is also to understand the various ways in which intensification has been implemented, and to investigate the types of medium-density housing that best accommodate diverse demographic groups while supporting good

Initial problem – increasing population, changing demographic make-up, housing obsolescence

urban form.

Initial problem – increasing population, changing demographic make-up, housing obsolescence

Increasing population, decreasing household sizes, changing demographic groups

The population of New Zealand as a whole is estimated to increase by 17% between 2006 and 2030 (BRANZ 2007). Wellington's population grew by 16,000 people between 2002 and 2007 (Wellington City Council 2007), and is projected to grow from 188,500 residents to approximately 204,500 by 2026 (Wellington City Council 2007). The population is then expected to grow by a further 34,000 people by the year 2055 (Wellington City Council 2006).

The increase in population itself is enough to create the need for more housing. However, the issue is further complicated by the fact that household sizes are becoming increasingly smaller and demographic groups are becoming more diverse. The average Wellington household size has steadily decreased; from 2.7 people in 1981, to 2.55 in 2001, and is projected to decrease to 2.4 people per household by 2021 (Wellington City Council 2007). This will increase the demand for new dwellings further.

The reasons behind the decreasing household size are varied, but are all related to wider social changes. The traditional 'nuclear family' is declining in proportion while single person households and childless couples are on the rise. Currently 28% of New Zealand households consist of two parents and two children (projected to decrease to 21% by 2026), while childless couples make up the same proportion (BRANZ 2007). The ageing population is contributing to the increase in people living alone, as are high divorce rates. Single-parent families are increasing in proportion due to declining marriage rates and increasing divorce rates (Dixon and Dupuis 2002). The average marriage age for men and women has increased from 23 and 20.8 respectively in 1971, to 29.3 and 27.5 in 2001 (Dixon and Dupuis 2002). Therefore there are now more single-person households than previously. This is also reflected in falling fertility rates as many people are choosing to have a career before or instead of raising children (Forster 2006). The baby boomer generation are now empty nesters, and their children are forming their own households (Bartley 2009).

Other factors influencing household makeup are economic – many young professional singles and couples are renting and delaying home-ownership or children because home affordability has significantly decreased since the previous generation (BRANZ 2007).

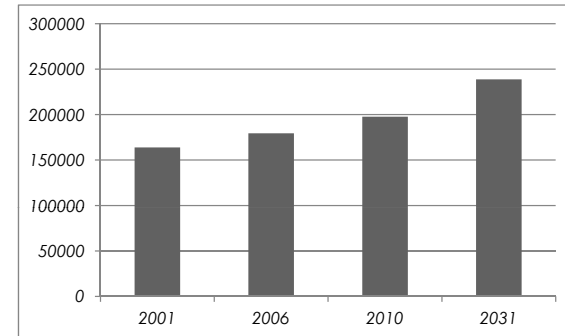

Figure 1.1 – Wellington projected population growth

Source: Authors own image, compiled from various sources

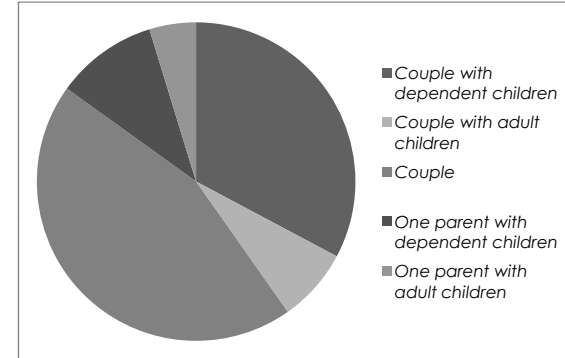

Figure 1.2 – Wellington current demographic household make-up

Source: Authors own image, compiled from various sources

In a study of the demographic groups residing in medium and high density housing forms in Sydney, the authors found that the socio-economic groups were extremely varied in terms of income, education level, family structure and country of birth (Bunker, Holloway et al. 2005). Immigration has led to a more ethnically diverse population; BRANZ (2007) identifies Asians as the fastest growing ethnic group in New Zealand, and also as the fastest growing group of homeowners.

Household numbers are often not static for many people. 'Patchwork' families, those whose families are combined through divorce and remarriage will often have fluctuating numbers of children staying at any one time (Weidinger 2010). Working from home has become more common as technology enables greater communication and remote connections (Moos and Skaburskis 2008). Therefore the relationship between work and home is becoming more fluid for many people, with more houses needing to be able to support income generation.

All the literature agrees on the main social and economic factors causing significant changes to demographic makeup. Where the authors diverge is on the implications these issues are having on housing demand.

Demand for housing

New Zealand is a very highly urbanised country; 87% of the population live in urban areas (Ghosh and Vale 2006). This percentage is only expected to grow, with immigration one of the main causes. Therefore new housing is primarily needed within the urbanised areas of the major cities. The Wellington region is projected to have the second most undersupplied housing stock in New Zealand by 2031 (Department of Building and Housing 2010).

The changing nature of demographic groups has an obvious flow-on effect to the demand for housing. Declining household sizes mean that projections for new households are of a higher percentage than projections for population growth. Wellington City Council estimates that an extra 30,000 dwellings will be needed by 2050 (Kos 2006), with 30% of this being medium-density housing (Department of Building and Housing 2010).

The housing shortage is further exacerbated by the fact that many of the emerging demographic groups have different lifestyle needs and preferences from the traditional family that existing detached houses cater for. This, along with ageing and disrepair, is leading to widespread obsolescence among the current housing stock.

Change and increase in demand

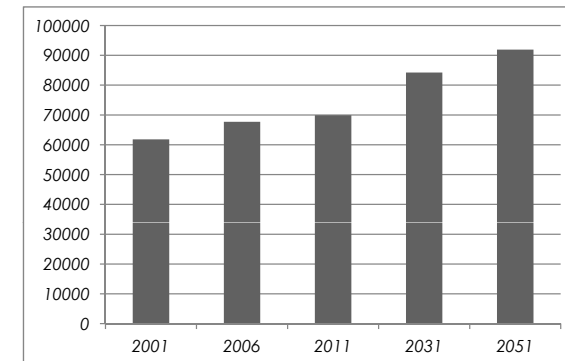

Figure 1.3 - Wellington projected housing growth

Source: Authors own image, compiled from various sources

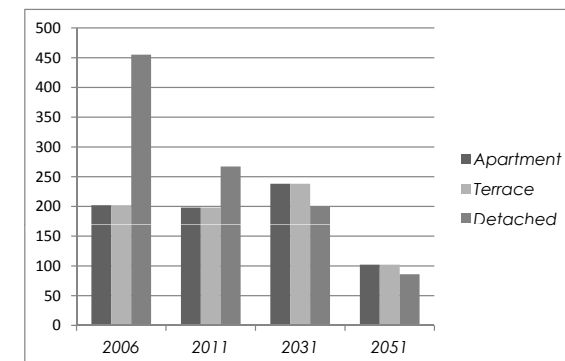

Figure 1.4 - Wellington projected dwelling type demand

Source: Authors own image, compiled from various sources

Initial problem – increasing population, changing demographic make-up, housing obsolescence

Wellington’s current housing stock is 66% detached suburban housing (Wellington City Council 2007). Projections by the Department of Building and Housing state that 60% of future demand will be for medium and high density dwellings, while 40% will be for more traditional detached housing (2010).

It is often assumed that smaller households will automatically want smaller houses (Farris 2010). The Wellington City Council has based much of its growth strategy on this assumption, identifying strategies to increase the amount of intensive housing forms. However, a study by Wulff, Healy et al. (2004) found that there is little hard evidence to support the claims that smaller households will move into smaller houses. Many single people living alone still wanted three bedroom houses if they could afford it. Empty nesters are a demographic that can often afford a larger house, and want one to suit their lifestyle with room for visiting family and guests (BRANZ 2007). The BRANZ report also indicates that newly built homes have been steadily increasing in floor area. The average floor area of existing houses is 145m², while new houses are being built at an average of 203m² with 3.8 bedrooms.

There is however a trend to trade floor area for higher quality finishes and more stud height (BRANZ 2007). One of the demographic groups driving the trend for smaller or more intensive forms of housing are young professionals. Childless couples and singles want modern houses with little or no maintenance that are located in close proximity to jobs and recreation (BRANZ 2007).

The large proportion of elderly people living alone is also driving demand for more housing choice. Many elderly want to continue living in the neighbourhood in which they have spent much of their lives (Wulff, Healy et al. 2004). Emotional and social ties keep them in familiar locations, although typical suburban housing available may no longer be suitable for their lifestyle. This is the same with the baby boomer generation – they want to age in place, driving demand for houses that can adapt to their changing lifestyle as they continue to age (BRANZ 2007).

Obsolescence

There are two main factors identified in the literature causing the obsolescence of New Zealand’s housing stock. The first is that layouts and size are not suitable for many emerging demographic groups. The second is that the physical condition of many is deteriorating due to age or construction techniques.

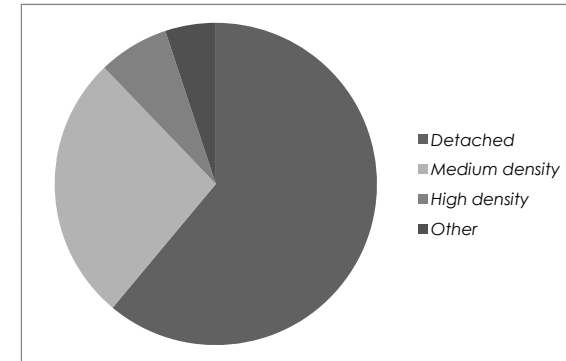

Figure 1.5 – Wellington current dwelling types
Source: Authors own image, compiled from various sources

The current housing stock consists mainly of detached three bedroom houses which are suitable for the traditional family, but have little relevance to the way people live today, and are lacking in modern amenities such as insulation, double glazing, well-connected outdoor space, and efficient circulation (Wulff, Healy et al. 2004; Bunker, Holloway et al. 2005). The New Zealand housing tradition developed along the lines of the quarter acre section, a form of development that is no longer sustainable because of the amount of land it uses (Dixon and Dupuis 2002).

Many houses, especially those built post-war are in need of major refurbishment, which can cost up to the same amount as building new (BRANZ 2007). The average life for New Zealand detached houses is generally between 90 and 110 years, dependent on the era in which a house was built, while Building Code standards provide for a 50 year life expectancy (Department of Building and Housing 2010). Early 20th century houses are in better condition than those built between the 1930s and 1950s due in the main to better quality construction. Many houses built in the 1990s have reduced life expectancies because of weather tightness issues (BRANZ 2007).

The existing detached housing stock will not adequately provide for the projected increase in population and households because it doesn't suit modern lifestyles and much of it is near the end of its life.

Urban issues of new housing provision

Detached houses take up a large amount of land, which has resulted in suburban sprawl in many Western cities (Churchman 1999). This is not a sustainable form of development for many reasons. Greenfield and agricultural land is wasted, large-scale infrastructure is needed to connect new suburbs and subdivisions to the rest of the city, and locating new development at the urban edge increases vehicle dependence. Urban form becomes fragmented, and results in highly segregated zones of activity (Jabareen 2006). The issues surrounding sprawl are very widely discussed, and well understood, so will not be gone into in any more detail here.

The physical form of Wellington precludes suburban sprawl. Its buildable area is closely confined between the rugged hills and the harbour. Therefore in order to increase the amount of housing available, new development will have to take place amongst the existing urban fabric. Much of the literature calls for urban densities to be increased in order to provide more housing while preserving open space.

Potential solutions – increasing density of existing urban form

Density is recognised in the literature as an incredibly complex issue to define and understand. Churchman (1999) recognises its importance to a wide range of disciplines – planning, urban design, architecture, environment-behaviour studies, transportation, economics, sociology, psychology, anthropology and ecology.

High density development is widely acknowledged to be an integral part of good urban form and efficiently-functioning cities. It means that land is used intensively, natural resources are protected, infrastructure is reduced, and public transport efficiency is increased (Churchman 1999; Brown and Cropper 2001; Jabareen 2006; Lunday 2006). It also enables residents to have more mobility and a greater range of social and cultural opportunities (Churchman 1999; Jabareen 2006).

There are negative implications of high-density urban environments recognised in the texts also. Issues of proximity, perceived crowding, reduction in privacy, increasing land costs, and traffic congestion are outlined by Churchman (1999) as possible outcomes of increased density. Some authors call for a reengagement with low-density sprawl, arguing that it has been given a bad name and that high-density development is more harmful socially and environmentally (Bartley 2009). However the general consensus amongst the literature seems to be that the benefits of high density urban form outweigh the disadvantages.

There is no consistently defined measurement of density. The literature acknowledges this – Jabareen (2006) defines it as either the ratio of people or dwelling units to area, while Churchman (1999) states that there is no accepted measure because numerators and denominators differ between countries. Types of land measurement units used vary, including square kilometres, square miles, and acres, making comparisons difficult. The inclusion or exclusion of non-residential land such as roads and open space also inhibits comparison (Goodchild 1994).

There is also no consensus in the literature on the 'right' amount of density. New Urbanist Peter Calthorpe recommends 7 units per acre as a minimum of residential density, which is reasonably low when compared to other authors. Rydin (1992) believes that the density needed for sustainable development is 30 to 35 dwelling units per hectare, or 14 per acre, double that of Calthorpe's. In a study done by Walton, Murray et al. (2008), they classified low density as 5.3 units per acre, medium as 12.5 per acre, and high as 17.4 per acre. The recommended amount of density to sustain a public transport system is approximately 40

persons per acre (2007), which, if household size of 2.5 persons is assumed, is equivalent to 16 dwelling units per acre. This is equal to Buxton and Tieman's estimation of the density of pre-war suburbs (Buxton and Tieman 2005). Jane Jacobs believed that the maximum residential density should be 200 dwellings per acre (Searle 2003), considerably higher than the other limits proposed, and probably best kept to inner city residential areas.

There are several current urban theories that promote increased density of existing urban form as their core strategy. Although they go under different titles, they share many characteristics: principally, limiting the boundary for urban expansion and replacing or filling in low-density areas with higher density built forms. Smart growth, compact city, transit-oriented design, and urban consolidation are all contemporary theories that incorporate these themes.

Smart growth and compact city

Smart growth and compact city both employ an urban growth boundary to control urban development.

Smart growth, a North American movement, calls for boundaries to be placed on the area in which a city can expand to. It is intended to direct future urban growth in a controlled way to limit sprawl (Danielsen, Lang et al. 1999). Critics point to the cost disparities of land on either side of the boundary line, they believe that by relaxing the boundary land will become cheaper and more readily available to new home builders (Bartley 2009). Some argue that there is a lack of quantitative evidence to support the claims of smart growth advocates (Phan, Peterson et al. 2009). The theory of an urban growth boundary has been incorporated into planning documents by many Australasian cities (Forster 2006), although recent studies show that in cities such as Melbourne and Sydney it hasn't been implemented in practice (Woodcock, Dovey et al. 2010).

The compact city approach is based on the model of European cities that have developed around pedestrian transportation to have a very high-density form. It is essentially a radial network spreading out from a defined city centre, with limits on development at the city edge (Churchman 1999). Many urban theorists advocate for newer cities to be planned along the same lines. Criticism of this idea points out that the current social, economic and technological context is completely different to the medieval context in which European cities developed (Peake 2006).

Arguments against this compact form of development with defined limits on expansion advocate for consumer choice, and many believe that consumers prefer low density detached housing, pointing to market demand as the key driver that has led to the dispersed form of many cities (Churchman 1999). It has also been demonstrated that planners have assumed that the changes to demographic makeup will facilitate implementation of compact city forms by increasing demand for smaller houses, but in reality there is little evidence to support this (Wulff, Healy et al. 2004).

Transit oriented design

Transit oriented design is often incorporated into compact city or consolidation strategies. It calls for higher density residential development to be strategically located at public transport hubs or along public transport corridors (Bunker, Holloway et al. 2005; Bartley 2009). In Melbourne there is a push to intensify development along tram routes. The theory is that by locating people close to public transport private vehicle usage will dramatically decline, and people can still be highly connected to amenities and services (Phan, Peterson et al. 2009). This is not necessarily the case, a study by Walton, Murray et al. (2008) found that new residents in a medium-density development located near public transport did not change their travel habits significantly. Similarly, Walton and Murray et al. (2008) found that increasing the amount of people in an area will also increase the amount of cars, which is unlikely to be offset by public transport.

18

Transit oriented design a planning tool that has been adopted by Auckland, seen as a key way to reduce traffic congestion in the city (Peake 2006). A study done in Melbourne found that building higher density housing to a maximum of five stories along transit lines would sufficiently accommodate projected growth without expanding development horizontally (Woodcock, Dovey et al. 2010). In another Melbourne-based study Bartley (2009) found that three to four storey development along arterial roads will accommodate projected growth, meaning that most residential areas can be left at their present low densities.

Consolidation

Urban consolidation works along similar principles to the urban growth boundary. It involves filling in the spaces and increasing the density of the existing urban fabric through infill, replacement, and redevelopment of existing sites (Michell and Wadley 2004; Bunker, Holloway et al. 2005; Forster 2006). It is one of the key urban development policies that Australia's main cities have been using to reduce greenfield development and preserve

open space (Phan, Peterson et al. 2009). Its urban form and environmental aims are in line with smart growth and compact city; to reduce car dependence, limit sprawl, provide more housing choice and make public transport more viable (Forster 2006; Phan, Peterson et al. 2009).

It is achieved through the use of more intensive housing forms, slowly moving from detached houses to medium and high density development by changing zoning ordinances (Searle 2003). Buxton and Tieman (2005) identify the three main ways in which consolidation can happen; local and central government policy; market-led redevelopment that is incremental and dispersed; or requirements for higher density development for planning approvals at the urban fringe.

Searle (2003) identifies some of the potential limits on consolidation as infrastructure capacity, land capacity, and market demand. Infrastructure may need to be replaced or upgraded to meet the impact of more users. Local residents may oppose higher density development in their neighbourhood, and, although demand for smaller dwellings is forecast due to shrinking household sizes, many of the small household demographic groups do not necessarily want smaller houses (Wulff, Healy et al. 2004).

All these urban development theories and strategies have similar goals: to reduce sprawl, preserve open space, reduce infrastructure costs, provide more housing choice, make public transport more efficient, and reduce vehicle emissions. Local governing bodies in New Zealand and Australia have implemented part or all of these strategies into their planning policies.

Housing strategies

Built form is crucial in order to achieve the goals outlined in the urban theories and strategies above. In order to increase residential densities within existing city boundaries, alternatives to the detached house must be used. Residential intensification and infill development were all identified in the literature as key to implementing the noted urban form goals.

Residential intensification and infill

Residential intensification is the process of replacing or redeveloping low-density areas with medium and high density housing forms. Infill development consists of filling in any gaps in the urban or suburban fabric, again with a higher density form of housing. Both of these strategies consolidate the existing suburban fabric, increasing a city's density without increasing its area.

Locating intensification and infill

From the research into current urban theories that promote higher density urban form, several conclusions on where to locate residential intensification were reached. There was general agreement in the literature that in order to reduce traffic congestion high density housing is best located close to public transport; either at a public transport hub or interchange; or along a well serviced route (Bunker, Holloway et al. 2005; Bartley 2009). Another recommended location for intensification is around local suburban centres, so that residents are within walking distance of shops and services (Phan, Peterson et al. 2009).

Inner-ring suburbs have been identified by many authors as more suitable for intensification than outer-ring suburbs because of their proximity to the central city (Peake 2006). They have also developed at higher densities than outer-edge post-war suburbs, so are more able to support higher density housing forms. Because of their age, intensification and gentrification can be used to revitalise and restore the ageing fabric (Bunker, Holloway et al. 2005).

It is estimated that 60 to 70% of new dwellings will be located within existing suburbs in Melbourne (Bunker, Holloway et al. 2005), a figure that is comparable to estimates of 60% for Wellington (Wellington City Council 2007). New medium-density forms can replace old detached houses as they become obsolete, so that density is increased slowly, and the morphological transformation is incremental (Myers 1992). Myers recommends pre-war suburbs that developed along gridded street and block patterns as the most suitable for

redevelopment because of the spatial and social attributes that are inherent in this urban form. Peake (2006) agrees, her space syntax analysis of the connectivity of three different street networks that developed around different transportation technologies showed that early suburbs built around pedestrian movement (i.e. those built before 1920) are the most highly connected, and have adapted well to change over time.

Intensive housing forms/typologies

Attached housing typologies are integral to achieving intensification. Medium-density attached housing types include semi-detached, duplexes, triplexes, low-rise flats, terrace, and townhouses (Bunker, Holloway et al. 2005; Lunday 2006). If built to a maximum of three stories, these forms are all at a similar scale to traditional houses, therefore they fit into the physical suburban context while increasing dwelling density significantly; between 25-70 dwellings per hectare (Dixon and Dupuis 2002). Attached housing has many environmental benefits too. Construction materials are reduced, as are heating and cooling costs because less wall surface area is exposed, while thermal gain is increased (Goodchild 1994; Bartley 2009).

Horizontally configured buildings such as flats are organised so that each dwelling unit takes up one level, with units stacked on top of each other. Townhouses and terraces are vertically configured, and are accessible from the ground plane, then progress up vertically.

Providing quality housing

A common theme among the studies into the satisfaction of attached medium-density housing residents was that basic design issues of layout, room sizes, and orientation were often inadequate, and adversely affected liveability.

Orientation to sun

North orientation of living areas is very important. Several texts identified this as a key consideration for enhancing liveability (BRANZ 2007; Ramirez-Lovering and Murray 2011). The benefits of proper orientation are pleasant living spaces and passive heating. Passive daylighting also contributes to pleasant internal spaces, so designers need to be careful to avoid overshadowing in areas of high density (Woodcock, Dovey et al 2010). Other passive environmental measures can be implemented such as having a single-loaded design to maximise cross-ventilation (Ramirez-Lovering and Murray 2011).

Layout, room sizes, proportions

22

Many residents of medium-density housing, and their neighbours, fear a loss of privacy (Vallance, Perkins et al. 2005). Ensuring that neighbours don't overlook private outdoor spaces can mitigate this (Bentley, Alcock et al 1985). Sufficient acoustic separation needs to be included. In a study of 15 medium-density communities one of the most common complaints was of a lack of acoustic separation between attached units, and excessive street noise (Syme, McGregor et al. 2005).

In the same study another common complaint was that internal layouts were unsuitable – issues included rooms that are too small, not enough bedrooms, rooms the wrong shape, and not enough storage space. Similar issues were identified in the BRANZ report (2007). Danielsen, Lang et al (1999) recommend a 5.5 metre minimum width for a sense of spaciousness and to facilitate a wide range of room arrangements. Shared party walls constrain layout options (Danielsen, Lang et al 1999).

Basic planning considerations of circulation, spatial adjacencies, orientation to sun, and connection to private outdoor space can enhance the liveability of a medium-density development. These objectives are all made more complex with attached housing but careful design can mitigate negative effects (Ramirez-Lovering and Murray 2011).

Providing diverse dwelling types for emerging demographic groups

In order to accommodate increasingly diverse demographic groups and dwelling structures a range of housing types and sizes need to be provided, while to be sustainable, medium-density dwellings need to be flexible enough to adapt for specific lifestyle needs of changing occupants over time.

Many medium-density developments have one type of dwelling repeated within the building envelope, reducing the diversity of the building's residents. Typical design strategies involve repetition of a single design, but if varying-sized units can be provided within a development resident choice is increased (Bunker, Gleeson et al 2002).

Myers (1992) believes that horizontally configured dwellings have the most potential for change because the floor plan can stay the same while the section changes, while Tice (1993) argues that vertically configured buildings are the most flexible and adaptable to different occupation. He points to English Georgian terraces that have supported a wide range of programmes over their lifetime.

Careful arrangement of rooms also can facilitate various habitation options, Ramirez-Lovering and Murray (2011) recommend separating bedrooms to opposite ends of the dwelling, and having flexible relationships between living, bedroom, recreation or work spaces. Minimising internal load-bearing walls enhances the dwelling's ability to be adapted in the future (BRANZ 2007).

Integrating new development into context

New Zealand has an entrenched history of detached houses on large sections; more intensive forms of housing are foreign to most of the public's notion of what a house is (Hoque 2001). One of the main obstructions to residential intensification is resident opposition. Residents are often afraid that the character and sense of place¹ that has built up in their neighbourhood over time will be destroyed when intensification is introduced (Syme, McGregor et al. 2005; Vallance, Perkins et al. 2005; Woodcock, Dovey et al. 2010). These oppositions stem from poorly designed developments that are out of scale with the context, or are of poor construction quality (Hoque 2001; Dixon and Dupuis 2002).

There are also negative social connotations with medium-density housing. Residents often associate it with public housing, believing that the quality of the socio-economic environment will be reduced (Smart 1985). Concerns about loss of privacy associated with over-looking are also common (Vallance, Perkins et al. 2005). These fears can be mitigated through high quality and considered design.

Design strategies

24

For new residential development, the existing built context can be addressed in three different ways: through the replication of the surrounding buildings and typologies; through the reinterpretation of the context in a contemporary manner; or through rejecting the context entirely.

Replication:

Replication involves copying historic forms and motifs, and applying them to contemporary development. New Urbanism employs this tactic in many of their residential developments in order to make their plans more acceptable to residents (Duany 2011). Many critics accuse New Urbanists of facadism, and Smart (1985) and Goodchild (1994) both argue that merely replicating historical styles doesn't support the piecemeal way in which suburbs grow or adapt to change. It also doesn't advance architectural development.

Reinterpretation:

¹ Sense of place, or *Genius loci*: Genius loci is defined as the spirit of a place. It is a key theme in phenomenological readings of place and architecture. Key proponents of this theory are Christopher Alexander and Kevin Lynch, who call for architecture to draw upon the local qualities and characteristics of a place that have evolved over time.



Figure 1.6 – Houses in Seaside, Florida - this New Urbanist development replicates traditional house forms

Source: Houses in Seaside, Florida. Retrieved from <http://www.dkolb.org/sprawlingplaces/generalo/newurban.html>



Figure 1.7 – House in Alcobaça, Topos Atelier de Arquitectura - the new corner house continues the pattern of fenestration and small upper-floor balconies

Source: Retrieved from <http://www.archdaily.com/188848> King, Victoria. "Berta Viana Office / 100 Planos Arquitectura" 06 Dec 2010. ArchDaily. Accessed 18 Oct 2011.

Reinterpretation is a strategy of taking the architectural elements of the existing context, and recombining or reinterpreting them in a way that is contemporary, but still recognisable as belonging to a particular place (Lynch 1960; Smart 1985; Goodchild 1994). In this way new development integrates into the fabric while evolving it at the same time. The sense of place and character can be kept intact, or enhanced by the new development.

Rejection:

Rejection happens when the existing context, scale, forms, and built typologies are ignored, and something of a different nature is inserted into the fabric. This design tactic is seen often in practice, but it is not promoted in the literature as it is one of the main reasons for community opposition to intensification because it detracts from the sense of place and character (Smart 1985; Weidinger 2010).

Of these three strategies, reinterpretation of the existing context is the most advocated-for approach within the literature because it respects the tradition of a place while still advancing architectural typologies and contemporary design. Most authors agree that new development can be successfully integrated into a historic fabric if it is sympathetic with the built form and typologies (Smart 1985; Hoque 2001; Lunday 2006). The specific character or sense of a place should be retained and used as a primary design driver.

The process for designing within a historic context should begin with a careful examination of the site according to Thomas (1996). Looking at old maps to understand the gradual process of subdivision and ever-refining urban grain will help to predict the next step in the evolution of the fabric (Thomas 1996). Morphological development, including street networks and block patterns should be studied to form an understanding of how an area came to its present form (English Partnerships and Corporation 2007).

Using local construction materials ties the design to the wider local context, and celebrates the specificity of a place (Danielsen, Lang et al. 1999). Retaining underlying rhythms and proportions can help new development assimilate into the context, and even enhance reading of the existing forms (Smart 1985).

Careful massing can also reduce the perception of density. A graduate study using photographs of streets with the same amount of dwellings found that the street that was perceived to be the least dense was actually the densest. Between each unit was a recess, giving the illusion of separation. There was also a high level of more complex massing such as bay windows and



Figure 1.8 - 1028 Natoma Street, San Francisco, Stanley Saitowitz - an example of rejecting the context - the Victorian townhouse form is ignored and an unsympathetic modern block is inserted

Source: Retrieved from <<http://www.archdaily.com/27802>> Saieh , Nico . "1028 Natoma Street / Stanley Saitowitz | Natoma Architects" 06 Jul 2009. ArchDaily. Accessed 06 Sep 2011. <<http://www.archdaily.com/27802>>

recessed doors that made the development look more 'house-like' (Knack 1991).

The architectural elements most commonly identified in the literature for integrating new development were: height, scale, proportion, massing, rhythm, roofline, fenestration, articulation, materials, ground treatment, and landscaping (Knack 1991; Hoque 2001; Untaru 2002; Lunday 2006; Gehl 2010). These aspects can all be reinterpreted from historical or traditional types while still appearing contemporary.

Conclusions

There is a general consensus among the literature that cities need to increase the density of existing areas in order to accommodate a growing population and housing demand rather than expanding outwards into greenfield land. There is some disagreement about the best urban planning theories to enable high densities but they all have similar traits such as placing limits on urban expansion, locating new development close to public transport and intensifying within the existing urban fabric. They also have similar aims – reducing infrastructure costs, reducing vehicle emissions, preserving open space, revitalising local centres, and providing more housing choice for the public.

Residential intensification is seen as an architectural tool to achieve these goals. There is some disagreement about where exactly to locate it, whether within inner suburbs or along transit corridors. However, the literature is in agreement on the need to increase the diversity of dwelling types in the housing stock, and that new medium-density development is a good opportunity to achieve this.

It is widely accepted that resident opposition to intensification stems from designs that are insensitive to the context and local character. The literature agrees that this can be mitigated through design strategies such as reinterpreting local typologies and carefully considering issues of acoustic and visual privacy.

The aim of this research is to understand the different theoretical issues and approaches that have been part of contemporary discourse. A lack of knowledge in practice is evidenced by the number of intensification projects that solicit criticism. However, good precedents do exist in practice. The review of precedents will facilitate an understanding of the different approaches and seeing how they have been applied to other cities. The most suitable aspects will be selected and applied to Wellington, the case-study city. The case-study itself will then seek to create further knowledge by testing these theories and adapting them into new forms and applications. The research undertaken here will form a basis for the selection of precedents and for the design-case study.

Precedents review

Introduction

As discussed in the literature review, suburban residential intensification is a key tool in providing choice for a growing population and emerging demographic groups, while preventing urban sprawl.

The aim of the precedents review is to see how architects have dealt with the issues discussed. The architectural solutions offered will be analysed, and will help to inform the case-study design. Some of the projects are built, some are unbuilt.

This chapter has a progression similar to the literature review. First, designs that can accommodate a range of demographic groups and are adaptable to change are looked at, with the plan as the primary analytic tool. Next, complex internal configuration providing diversity is examined, where the section becomes paramount. Finally, designs that address the issue of integrating into a historical site are discussed. The focus here is on the elevation. These three aspects are considered separately, but elements from all of them will be incorporated into the case study design.

31

Responsive, adaptable housing - plan

The literature survey revealed that one of the most pressing problems created by a homogenous housing stock is the accommodation of emerging demographic groups and their diverse ways of dwelling. While single detached houses have been efficient for housing traditional families of parents and 2.4 children, demographic trends show that this family type is consistently decreasing, resulting in a surplus of detached house types.

In the literature survey some of the more common emerging demographic groups were revealed; including empty nesters, single-parent families, childless couples, singles, combined families, and multi-generational families. It was also shown that the inability of new houses to accommodate emerging demographic groups is a source of dissatisfaction largely due to inflexible layout and poor orientation.

The following precedent studies were selected for their attention to loose-fit, adaptable solutions that respond to site conditions and changing lifestyle need.

Diego Ramirez-Lovering, Two designs for the Sustainable and Affordable Home Initiative: Adaptable House and Dividable House, Australia (unbuilt)

The Sustainable and Affordable Home Initiative is sponsored by the Victorian Government, and its aim is to develop new housing models to accommodate Melbourne's growing population.

The Adaptable House is a design for a detached house suitable for a suburban context. It looks at density in a different way; rather than increasing the density of dwellings, it proposes to increase the density of people per dwelling. The house has a simple plan, but allows for various dwelling structures of different demographic groups. This is achieved by having a semi-detached multi-purpose room with separate access to the main house, and two internal sliding walls. By reconfiguring the spaces a variety of demographic groups can be accommodated. The house can be occupied by one household with different groups within it i.e. a couple plus elderly parents or grown children, or it can be occupied by two separate households (figure 2.1). The design recognises that there is no defined traditional family group anymore, dwelling structures can take many forms, and also change over time.

32

The Dividable House can act as one house, accommodating a large multi-generational family for instance, or it can be divided into two smaller dwellings suitable for smaller groups of related or unrelated households (figure 2.2). The plans support the fluctuating nature of dwelling structures. Split servicing and fire separation are included in the initial construction so that future division is simple and low cost. As a family's circumstances change over time, for example the children growing up and moving out, the parents can then divide the house and rent or sell the other dwelling.

Both of the projects by Ramirez-Lovering illustrate simple ways in which a house may be adapted to suit the occupation patterns and needs of a dwelling group over time. The plans have the potential to suit a wide variety of people and family structures.

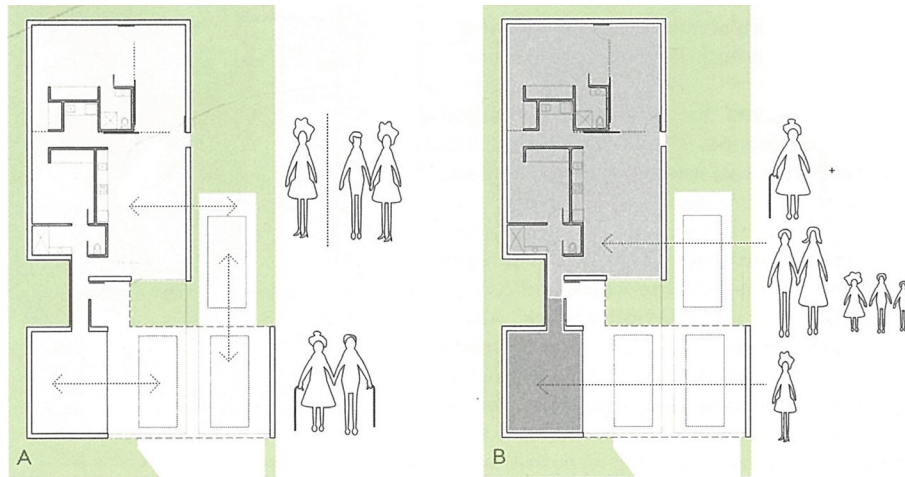

Figure 2.1 - Adaptable House (Diego Ramirez-Lovering), two possible occupations

Source: Reproduced from Murray, S., D. Ramirez-Lovering, et al., Eds. (2008). *reHousing: 24 housing projects*. Melbourne, Copyright 2008 RMIT University Press, p. 107.

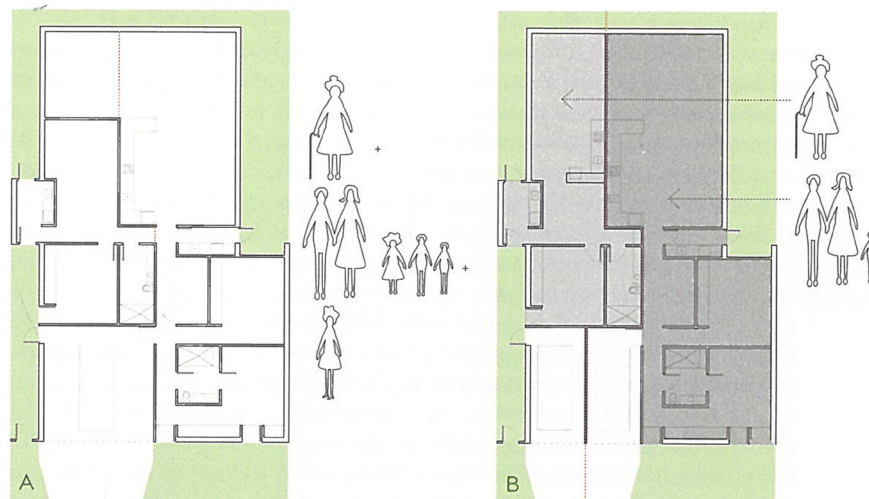

Figure 2.2 - Dividable House (Diego Ramirez-Lovering), two possible occupations

Source: Reproduced from Murray, S., D. Ramirez-Lovering, et al., Eds. (2008). *reHousing: 24 housing projects*. Melbourne, Copyright 2008 RMIT University Press, p. 108.

Marco Calvino, Compact Courtyard House, Australia (unbuilt)

The Compact Courtyard House is based on a six-square grid, with one of the squares always being an open courtyard. Depending on the orientation of the house, the courtyard changes position to best draw in natural light and ventilation (figure 2.4). The other squares are living spaces, bedrooms and garages which can be combined in different amounts.

In plan the house is flexible; it can be adapted to suit various dwelling structures and can be one or two storeys. Living areas open out to the courtyard, providing a strong connection with private outdoor space.

The single house is the building block in a wider urban application. It is designed to fit within existing suburban forms; the scale is suitable for typical Australian plot sizes. Because the design is responsive to site conditions it can be applied and modified across a wide area. The addition of the courtyard allows higher dwelling densities to be reached because less open space needs to be provided around the house. Repeating the unit creates a defined street front. As seen in the figure-ground plans the houses can be combined in different ways on an existing block, significantly increasing the dwelling density while still providing many of the amenities of a traditional detached house such as ground plane access, street frontage, private outdoor space, sun, and natural ventilation (figure 2.6).

The designs by Ramirez-Lovering and Calvino both recognise the need for new houses to be flexible and capable of supporting various demographic groups and changing lifestyles. The plans are responsive to site conditions and are capable of increasing the dwelling density of existing areas.

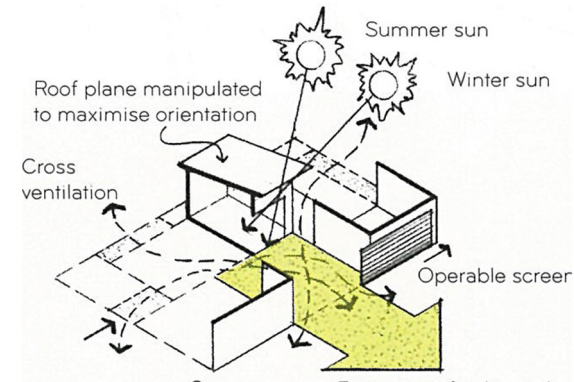

Figure 2.3 - Compact Courtyard House (Marco Calvino)

Source: Reproduced from Murray, S., D. Ramirez-Lovering, et al., Eds. (2008). *reHousing: 24 housing projects*. Melbourne, Copyright 2008 RMIT University Press, p. 114

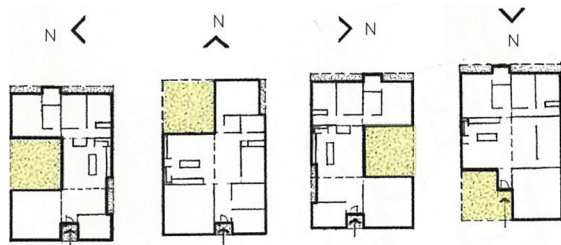

Figure 2.4 - Compact Courtyard House (Marco Calvino), designing for solar orientation

Source: Reproduced from Murray, S., D. Ramirez-Lovering, et al., Eds. (2008). reHousing: 24 housing projects. Melbourne, Copyright RMIT University Press, p. 114

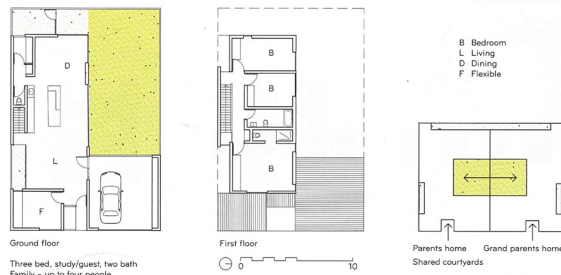
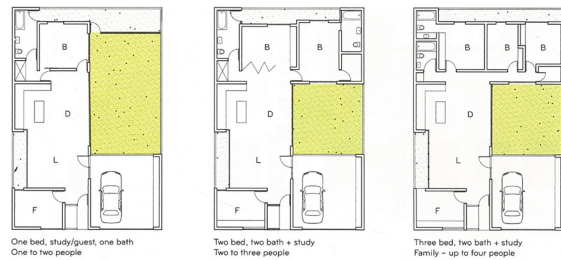

Figure 2.5 - Compact Courtyard House (Marco Calvino), various plan arrangements

Source: Reproduced from Murray, S., D. Ramirez-Lovering, et al., Eds. (2008). reHousing: 24 housing projects. Melbourne, Copyright 2008 RMIT University Press, p. 115

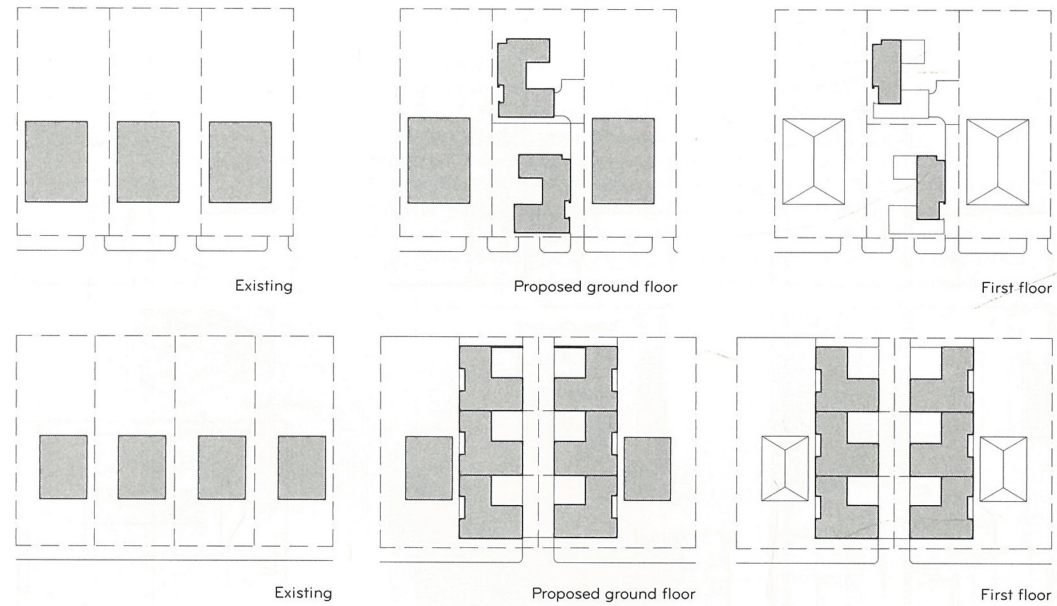

Figure 2.6 - Compact Courtyard House (Marco Calvino), suburban intervention

Source: Reproduced from Murray, S., D. Ramirez-Lovering, et al., Eds. (2008). reHousing: 24 housing projects. Melbourne, Copyright 2008 RMIT University Press, p. 116

Internal configuration providing diverse dwelling types – section

The general consensus in the literature review was that medium-density residential buildings with vertical internal configuration were best able to support higher densities while still having many of the amenities of a traditional detached house.

While selecting precedents to review it became clear that complex internal configuration rather than typical horizontal or vertical configuration offered a far more diverse range of dwelling types within a single building envelope. By altering the section the range of dwelling sizes could be significantly increased and the types of internal spaces and layouts were also increased. Therefore dwelling choice is wider and the development is far more attractive to a more diverse group of people.

JDS + BIG, VM Houses, Copenhagen

Although this building is classified as high-density rather than medium-density its internal arrangement can be applied to smaller developments.

The building varies in section throughout, producing more than 80 unique dwelling types amongst the 209 apartments (figures 2.8 and 2.9). By interlocking individual units horizontally and vertically, apartment sizes and spaces are able to be widely varied. Different numbers of bedrooms and types of living space appeal to different family groups resulting in a non-homogenous residential population.

The types of dwellings range from single-floor plans to triplexes. Rooms are large and open, and can be divided into smaller spaces with screens or partition walls according to resident preference.

Spatial interlocking also provides sunlight and views to every apartment. Internal spaces are varied, with many double-height living areas. Natural light comes from the extensive glazing while each apartment has a south-facing balcony.



Figure 2.7 - VM Houses (JDS + BIG)

Source: Retrieved from <<http://www.archdaily.com/970>>
Saieh, Nico. "VM Houses / PLOT = BIG + JDS" 19 May 2008.
ArchDaily. Accessed 02 June 2011.

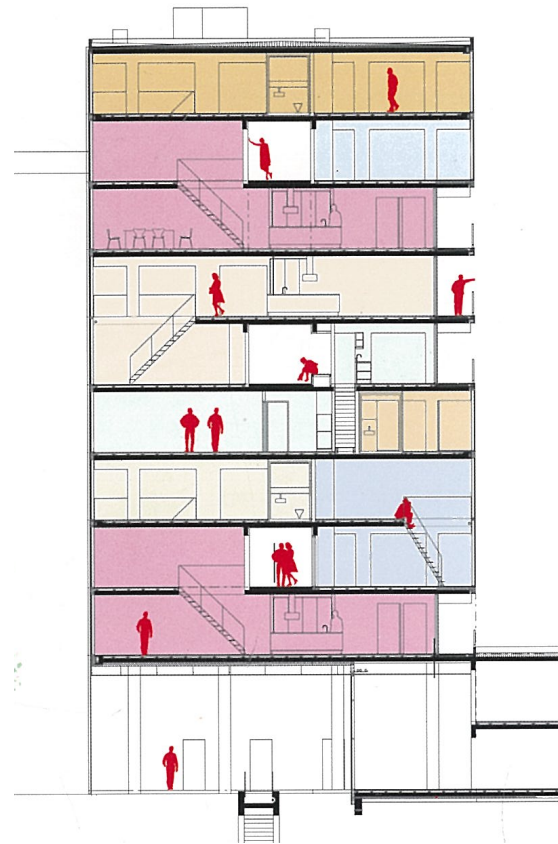

Figure 2.8 - VM Houses (JDS + BIG), Building M cross section

Source: Reproduced from Duran, S. C. (2009). High Density Housing Architecture. Barcelona, Copyright 2009 Loft Publications. p. 182



Figure 2.9 - VM Houses (JDS + BIG), Building V cross section

Source: Reproduced from Duran, S. C. (2009). High Density Housing Architecture. Barcelona, Copyright 2009 Loft Publications. p. 182

MVRDV, Double House, Utrecht

This house arose as a solution to the constraints of having to accommodate two families, while not sacrificing the attributes of the site for each house. The section is dynamic; the party wall zig-zags up through the house creating varied room sizes, shapes and orientations (figure 2.11). The interior spaces of the two houses are interlocked three-dimensionally (figure 2.12). Figure 2.13 illustrates the design development of the complex configuration. By manipulating the party wall in section, both houses are able to have living areas that take up nearly the whole width of the site, maximising space, light and views. They also both retain ground floor access to the garden and ground floor entrance from the street – key traits of the traditional detached house. Rather than producing two equal-sized dwellings by splitting the house in half vertically, one house takes up two-thirds of the space. By providing different-sized units they are more suitable for diverse household sizes.

Both of these projects demonstrate how complex internal configuration can produce a wide range of dwelling types and sizes, increasing choice and resident diversity.



Figure 2.10 – Double House (MVRDV)

Source: Reproduced from Levene, R, Marquez Cecelai, F Eds. (1998).MVRDV, Copyright 1998 El Croquis. Barcelona. p. 123

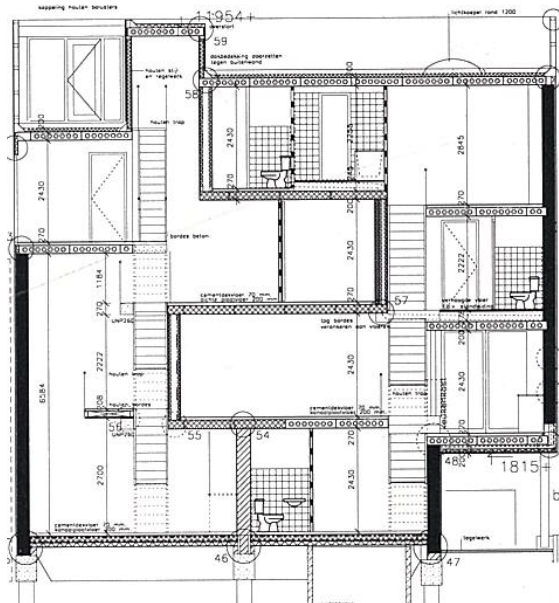

Figure 2.11 - Double House (MVRDV), section
 Source: Reproduced from Levene, R, Marquez Cecelai, F Eds. (1998).MVRDV, Copyright 1998 El Croquis. Barcelona. p. 126

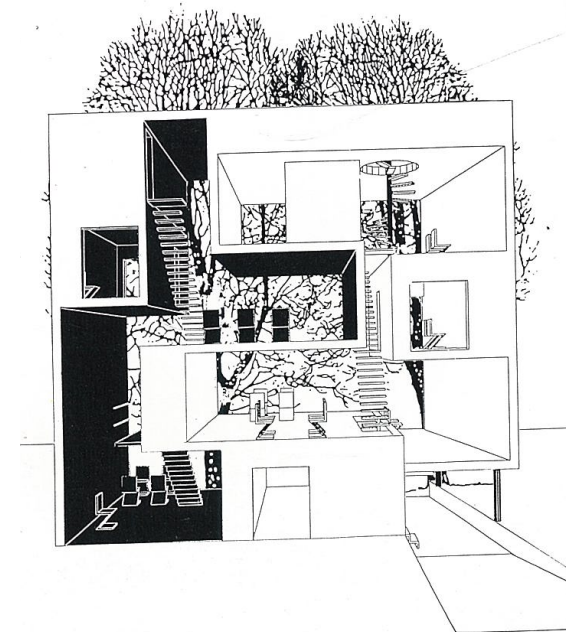
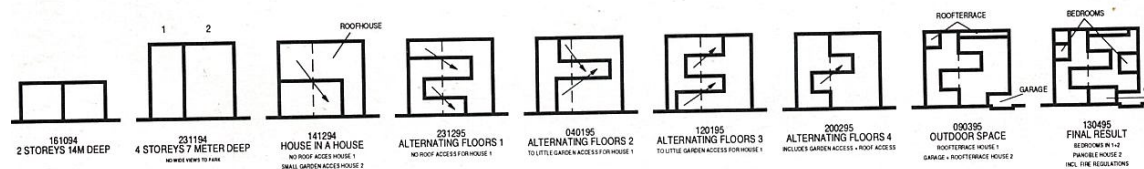

Figure 2.12 - Double House (MVRDV), sectional perspective
 Source: Reproduced from Levene, R, Marquez Cecelai, F Eds. (1998).MVRDV, Copyright 1998 El Croquis. Barcelona. p. 122

Figure 2.13 - Double House (MVRDV), development diagram

Source: Reproduced from Levene, R, Marquez Cecelai, F Eds. (1998).MVRDV, Copyright 1998 El Croquis. Barcelona. p. 122



Integrating new development into historical fabric – elevation

An important factor in building new housing in established neighbourhoods is integration with the existing context. The literature review revealed that most people object to intensification in their neighbourhood because of perceptions that the new development will detract from the existing character or sense of place that has developed over time. This also leads to fears of devalued property and reduced amenities such as noise, light, privacy, and views. The literature review also established design strategies that can be used to integrate new development into a historic context. These precedents will be evaluated according to the criteria identified earlier in the literature review; proportions, massing, fenestration, entrance, roofline, articulation, materials, and colour.

Kerstin Thompson, Gore Street Housing

A medium-density block of houses is introduced to a traditional street in Fitzroy, one of Melbourne's earliest planned suburbs. There are 21 dwellings, each with one or two bedrooms. Each unit is spread vertically over two or three storeys, with voids and courtyards allowing for light penetration. The overall block fits in with the scale of the neighbouring buildings, and the street edge is continued and respected.

The building is tied firmly to its context while not denying its contemporary design and programme. Material and massing integrate the building into the streetscape while retaining a modern appearance.

Proportions: The surrounding buildings reach a height of two storeys, so the three-storey block is at a relatable scale. The stacked nature of the internal units is expressed through fenestration and material patterning to define individual houses within the block.

Massing: The building is built out to the same line as its neighbour providing visual continuity and framing the street edge. Terraces on the second floor reduce the mass to sit more comfortably next to a two storey building.

Fenestration: The windows and screens are larger than those of the neighbouring building, but are aligned horizontally

Entrance: Street front entrances are retained, continuing the active edge of the street.

Roofline: The flat roofline is broken up by the addition of terraces.

Materials: The same material palette of the surrounding context is used, but in a contemporary manner. The traditional red brick is reinterpreted, and used as a screening and light-filtering device as well as a solid wall.

Articulation: The changing texture of the brick, from wall to screen, provides visual interest.

Colour: The colour palette is replicated – the red brick and white detailing found on the historic neighbour is translated directly into the new building. The contextual colour palette is referenced through the white screens, drawing parallels with the thick white window frames of the historical building next door.

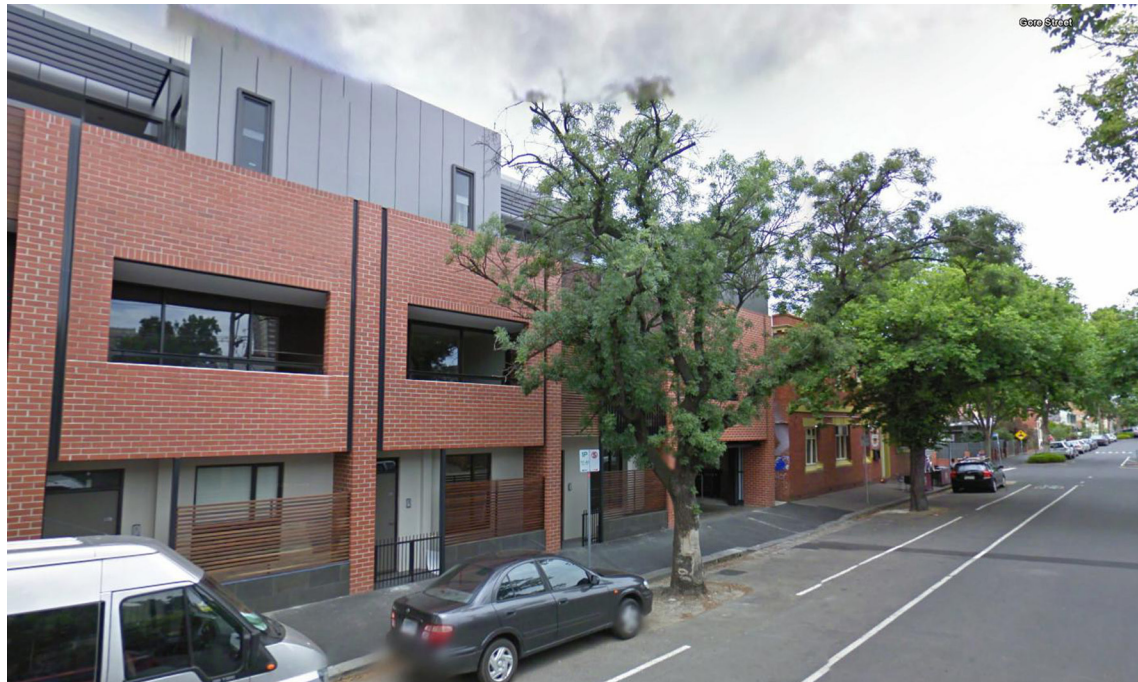

Figure 2.14 - Gore St Housing (Kerstin Thompson), street perspective
Source: Google Earth. 2008. June 24 2011.

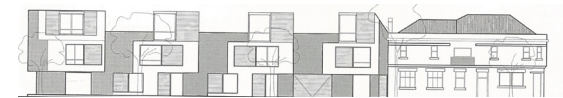

Figure 2.15 - Gore Street Housing, (KerstinThompson) elevation

Source: Reproduced from Murray, S., D. Ramirez-Lovering, et al., Eds. (2008). reHousing: 24 housing projects. Melbourne, Copyright 2008 RMIT University Press, p. 23



Figure 2.16 - Gore Street Housing (Kerstin Thompson), street perspective

Source: Reproduced from Murray, S., D. Ramirez-Lovering, et al., Eds. (2008). reHousing: 24 housing projects. Melbourne, Copyright 2008 RMIT University Press, p. 22

Onion Flats, Thin Flats, Philadelphia

In Philadelphia, Onion Flats designed the Thin Flats as a modern reinterpretation of the traditional Philadelphia row house. They interpreted the vertical rhythms and patterns, and transformed them into a masking device, questioning the distinction between individual homes.

Proportions: The new development keeps to the same height as its neighbours. The vertical rhythms of the row house are retained and made more prominent by contracting them together

Massing: The building is built to the street edge, which is retained right up the height of the building, like its neighbours. Recesses form balconies, which are a newly introduced architectural element to the area, but they are carefully scaled to be similar to the window sizes

Fenestration: The vertical rectangular windows are similar in size and proportion to the older buildings. They are staggered across the facade rather than distributed regularly, in an abstraction of the traditional facades.

Entrance: Street level entrances are retained, although the traditional stoop is not.

Roofline: The roofline echoes the staggered nature of the closely-knit buildings, with slight height changes and parapets mimicking the connections between the neighbouring buildings.

Materials: The playful arrangement of facade panels and glazing take on an abstracted appearance, as if the elements of the traditional houses have been reassembled into a new composition. The refined modern construction materials don't jar when juxtaposed against the traditional red brick facades.

Articulation: Articulation of windows is reduced by using modern construction, but this fits with the semi-industrial appearance of some of the surrounding buildings. Vertical rhythms are enhanced by raised edges, dividing the facade into ribbons.

Colour: The palette is neutral, shades of grey and white harmonise with the neighbouring brick walls. The traditional red brick facades are referenced through the colours glimpsed on the interior walls of the balconies, rather than a literal interpretation

Although the development looks contemporary, careful reinterpretation of the traditional architectural elements has allowed it to sit comfortably within its context, without detracting from the historic character.

The two projects show different ways in which new development can be integrated into a historical context. Gore Street Housing uses materials in a direct translation of the context with some subtle manipulations, while Thin Flats relies on the complementary nature of a historic material juxtaposed with a modern one. Both use height, massing and proportions carefully to ensure that the new development is appropriate for the existing scale.



Figure 2.17 - Thin Flats (Onion Flats), street perspective

Source: Thin Flats. *Onion Flats*. Retrieved August 03, 2011, from <http://www.onionflats.com/#/Work/>



Figure 2.18 - Thin Flats (Onion Flats), elevation

Source: Thin Flats. *Onion Flats*. Retrieved August 03, 2011, from <http://www.onionflats.com/#/Work/>

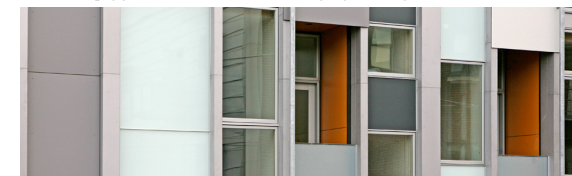

Figure 2.19 - Thin Flats (Onion Flats), windows detail

Source: Thin Flats. *Onion Flats*. Retrieved August 03, 2011, from <http://www.onionflats.com/#/Work/>

Conclusions

The review of precedents has examined built examples of ways in which the various issues raised in the literature review have been addressed. Dwellings that respond to changing lifestyle needs, and enhance liveability through orientation and response to climate illustrate high quality planning. Complex internal configuration provides diverse living spaces and dwelling sizes, which can accommodate a broad range of demographic groups, and increase housing choice. Various ways in which local context can be reinterpreted in order to enhance integration were made apparent.

The lessons taken from the precedents will be adapted in the case-study to suit the specific site chosen.

Design case-study

Introduction

The purpose of the case study is to investigate ways in which residential intensification can occur in Wellington's suburbs. The aim is to design medium-density housing that is appropriate for its site conditions (in particular sun and street orientation), that can accommodate a range of demographic groups and family sizes, and that is sensitive to the built context and character of the place in which it sits. This is achieved through:

- a study of Wellington's suburbs, establishing the selected ones as the best locations for intensification;
- planning internal arrangements for liveability and potential for future adaptation;
- experimentation with overlapping and interweaving sections to achieve a variety of dwelling sizes in one unit;
- close study of the built context of a selected site, which is then reinterpreted in order to integrate the design into its surroundings.

From the case study, a set of principles for the planning and design of medium-density housing is extrapolated, which can be applied to any of the studied sites across Wellington, and may have potential to be applied in other cities with similar suburban morphology.

Part A - Site analysis

Wellington

Wellington's natural basin-like form has led it to develop as a compact city, concentrated towards the harbour. There is limited land for future growth due to its extreme topography, and expansion is not desirable as it will undermine the current compact, easily navigable nature of the city.

Wellington's extreme topography has led to the development of two main suburban organisation typologies; the regular street grid on flat land, and the irregular, windy streets on steep land.

Early development of Wellington was built on whatever flat land the settlers could find. While initial plans had been drawn up to develop Wellington on a classical grid, similar to those seen in other colonial cities such as Melbourne and Adelaide, the realities of the land's physical nature resulted in huge distortions to the original plan. Due to the limitations inherent in the construction technologies of the day, the settlers were forced to fit elements of the grid plan onto any flat land that they could find (Brand 2004). The 1840 grid plan was first laid out at Lambton Harbour, and then was squeezed through the valley formed between Mt Cook and Mt Victoria, before expanding again to form the suburbs of Berhampore and Newtown (figure 3.1).

Early development involved subdividing and selling lots within the initial one acre blocks

56

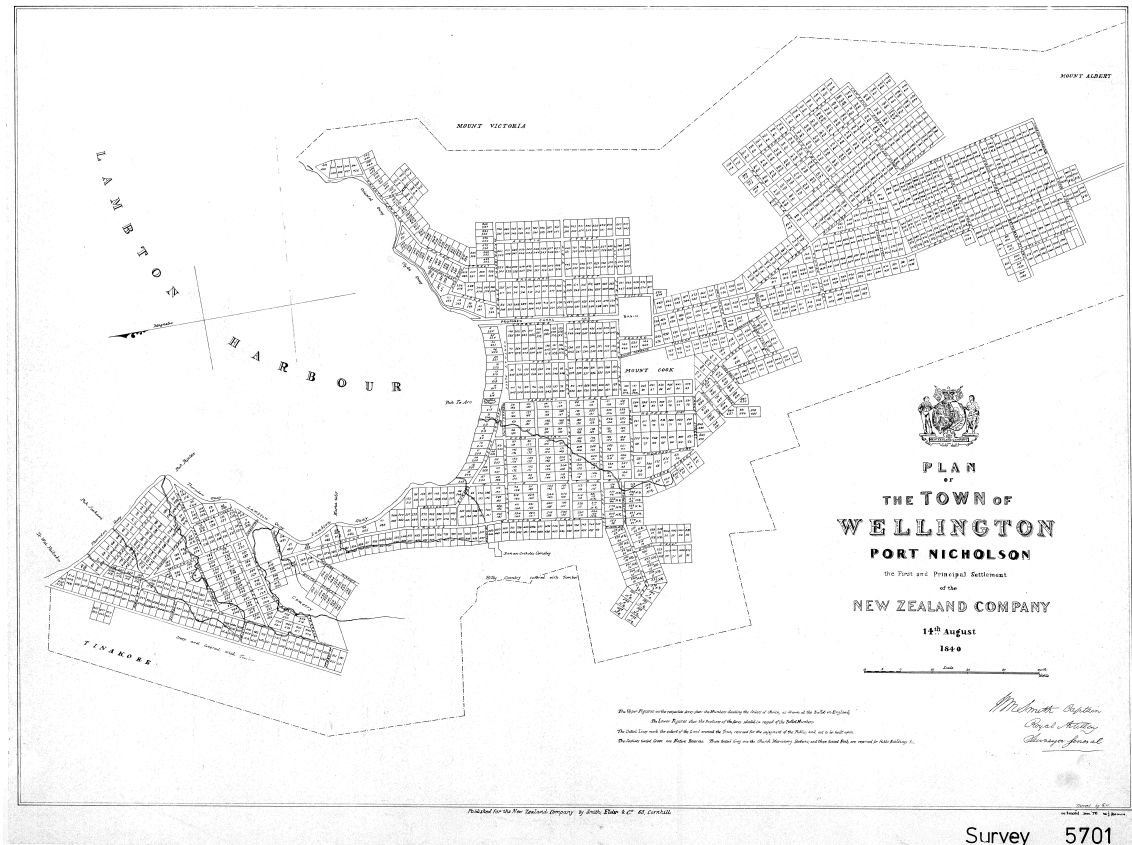

Figure 3.1 - Plan of the town of Wellington, Port Nicholson, 14 August 1840

Source: Wellington City Archives

Survey 5701

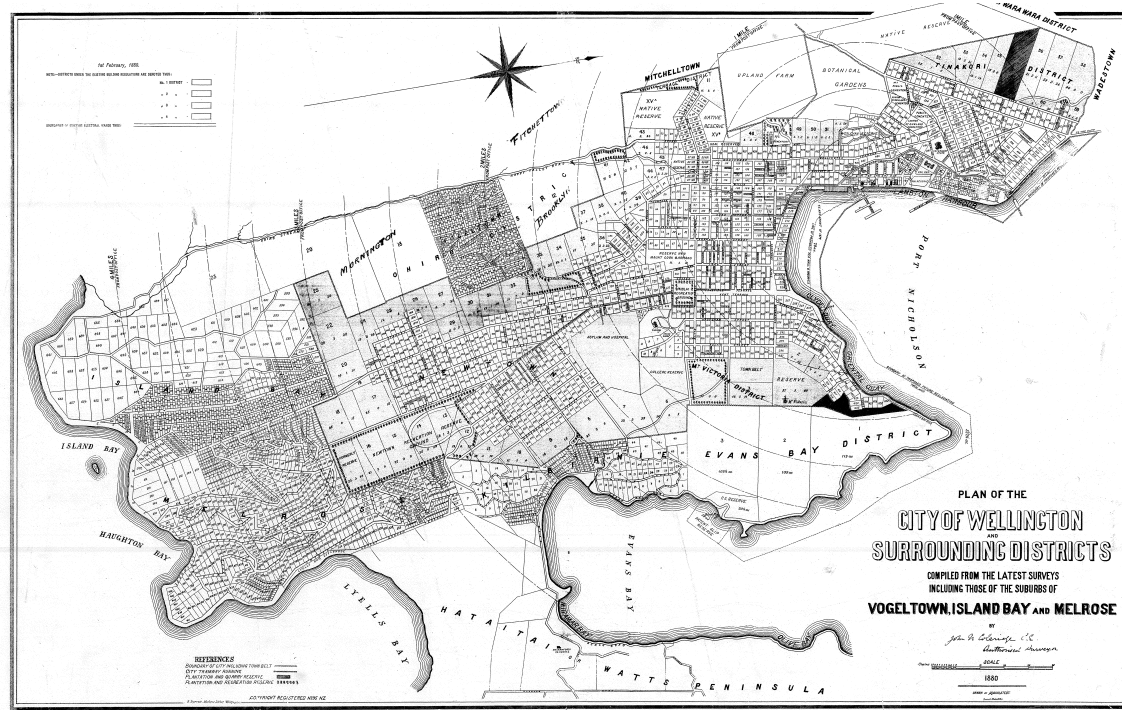

Figure 3.2 - Plan of the city of Wellington and surrounding districts, 1880
Source: Wellington City Archives

created by the street grid. Expansion later in the 19th century, into suburbs such as Island Bay, Kilbirnie, Lyall Bay, Seatoun, Miramar and Karori, followed the same pattern of laying out a grid plan on any available flat land, then subdividing blocks into residential-sized lots (figure 3.2). Most blocks were subdivided by developers, who then placed rows of similar or identical speculative housing on them to be sold off to individual owners. These lots had very narrow street frontages, enabling developers to fit more houses on a site, thereby generating more profit.

Eventually suburbs started to expand to the hills surrounding the flat land. The nature of the hills forced streets to wind back and forth, twisting and turning up steep inclines. It proved impossible to divide areas into regularly sized and shaped blocks, and each site was unique in terms of gradient, view, and sun exposure. Most Wellington suburbs are a mixture of these two morphological types (figures 3.3, 3.4, 3.5).

The examination of these two types of street networks shows that residential intensification is best suited to the gridded street networks because they are more able to support increased pedestrian and vehicular traffic and the flat land is easier to build on.

58



Figures 3.3, 3.4 - Houses scattered amongst hills in Island Bay

Source: Author's own images



Figure 3.5 - Houses on gridded streets (mid-ground), houses dispersing into hills (back-ground)

Source: Author's own images

Figure 3.6 - Wellington, showing topography, suburbs, street network

Source: Author's own image



THORNDON

NORTHLAND

WELLINGTON CENTRAL

KELBURN

KARORI

ORIENTAL BAY

ROSENEATH

TE ARO

ARO VALLEY

MOUNT VICTORIA

HIGHBURY

MOUNT COOK

HATAITAI

MAUPUIA

KARAKA BAYS

BROOKLYN

NEWTOWN

VOGELTOWN

MAKARA

MORNINGTON

KILBIRNIE

MIRAMAR

KINGSTON

BERHAMPORE

SEATOUN

MELROSE

RONGOTAI

OWHIRO BAY

SOUTHGATE

STRATHMORE

BREAKER BAY

ISLAND BAY

HOUGHTON BAY

LYALL BAY

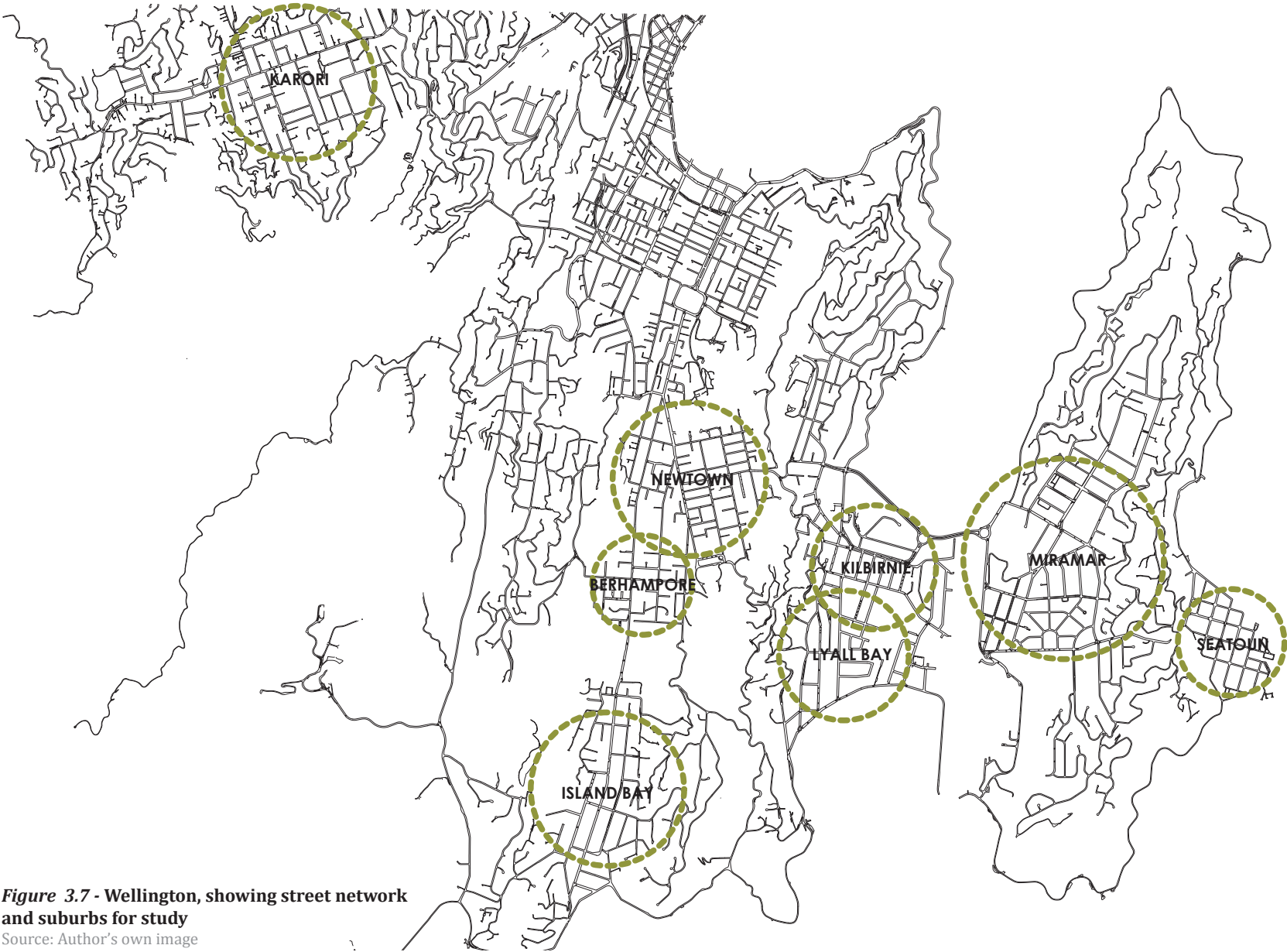

Figure 3.7 - Wellington, showing street network and suburbs for study
Source: Author's own image

Examining Wellington's suburbs: Density and housing demand

Eight suburbs were selected for study based on their proximity to the city centre and their urban form. All of the suburbs started to develop between 1840 and 1880, and all have a gridded plan at their centre, with more freeform arrangements in the surrounding hills.

The projected population growth (figure 3.8) shows that Miramar and Newtown both have significant percentage increases for 2030. Karori has the second-highest real increase but the lowest percentage increase because of its already large population.

The average household size was calculated by dividing the number of inhabitants of each suburb by the number of houses. Seatoun has the largest household size at 2.8, while Berhampore has the lowest of 2.3 (figure 3.9).

SUBURB	2006	2030	% INCREASE	ACTUAL INCREASE
KARORI	14007	16290	16.3	2283
ISLAND BAY	6951	8140	17.1	1190
BERHAMPORE	2595	3050	17.5	455
NEWTOWN	8409	10670	26.9	2261
LYALL BAY	3006	3670	22.1	644
KILBIRNIE	6429	7970	24	1541
MIRAMAR	8337	10970	31.6	2633
SEATOUN	2130	2560	20.2	430

Figure 3.8 - Residential population projected increase 2006-2030

Source: Compiled from 2006 Census data

SUBURB	HOUSEHOLD SIZE
KARORI	2.7
ISLAND BAY	2.7
BERHAMPORE	2.3
NEWTOWN	2.5
LYALL BAY	2.5
KILBIRNIE	2.4
MIRAMAR	2.7
SEATOUN	2.8

Figure 3.9 - Average household size 2006

Source: Compiled from 2006 Census data

The suburb with the highest dwelling density is Newtown, with 13.4 houses per hectare. Newtown also has the highest inhabitant density with 33.77 people per hectare. Miramar and Kilbirnie also have reasonably high densities. Karori, Seatoun and Lyall Bay are all low density with around 5 dwellings per hectare (figure 3.10).

The projected dwelling density was calculated by taking the projected population increase for each suburb and dividing it by 2.4 (Wellington City Council 2007), which is the projected average household size for Wellington in 2030. The results are consistent with the figures for 2006 - Newtown, Kilbirnie and Miramar are projected to have the highest densities. All increase by about four houses per hectare. Seatoun, Lyall Bay and Karori all remain low density, only increasing by about one house per hectare (figure 3.11).

SUBURB	AREA m ²	DWELLINGS	DENSITY DWELLINGS PER HECTARE	DENSITY INHABITANTS PER HECTARE
KARORI	11.09	5076	4.57	12.63
ISLAND BAY	2.33	2514	10.79	29.83
BERHAMPORE	0.97	1026	10.58	26.75
NEWTOWN	2.49	3336	13.4	33.77
LYALL BAY	2.58	1200	4.65	11.65
KILBIRNIE	1.97	2586	12.13	32.63
MIRAMAR	2.73	3084	11.3	30.54
SEATOUN	1.33	750	5.4	16.02

Figure 3.10 - Dwelling and inhabitant density 2006

Source: Compiled from 2006 Census data

SUBURB	AREA m ²	NUMBER OF NEW DWELLINGS*	TOTAL DWELLINGS	DENSITY DWELLINGS PER HECTARE	DENSITY INHABITANTS PER HECTARE
KARORI	11.09	951	6027	5.43	14.69
ISLAND BAY	2.33	496	3010	12.91	40.18
BERHAMPORE	0.97	189	1215	12.53	19.25
NEWTOWN	2.49	942	4278	17.18	40.46
LYALL BAY	2.58	268	1468	5.69	42.85
KILBIRNIE	1.97	642	3228	16.39	14.22
MIRAMAR	2.73	1097	4181	15.32	31.44
SEATOUN	1.33	179	929	6.98	34.94

Figure 3.11 - Projected dwelling and inhabitant density 2030

Source: Compiled from 2006 Census data

* Estimated number of new dwellings = projected population increase divided by estimated household size of 2.4

The investigation of future dwelling densities and projected housing needs for each suburb show that there will be some quite significant increases in density and hundreds of new houses will need to be provided within the existing suburban fabric. The next step is to investigate the urban form of the suburbs in order to identify where and how to locate future housing intensification.

Examining Wellington's suburban grids: Urban form

The following examination of the urban form of the suburbs discussed earlier will serve as a basis for the argument that medium-density residential development should be located within these areas.

The tools used to carry out this investigation were maps and aerial images from Google Earth and maps from Koordinates. Historical photos also help to illustrate the underlying grid network and how the urban form of each suburb has developed.

All of these suburbs are made up largely of detached, one-family houses (Wellington City Council 2007). Urban form aspects are examined and compared: street network, block sizes and shapes, subdivision pattern (lot sizes and shapes), positioning of houses on lots (relationship to street and neighbours), private open space, and typical house styles. By comparing these aspects similarities can then be identified, and used to develop over-arching principles for a medium-density housing design that is suitable for all these sites.

Karori: A continuous main road runs east-west through Karori, while the grid extends mostly towards the south from the main road, and lesser to the north. The grid itself is not regular; there are different block sizes, and some streets don't connect all the way through. The blocks are generally subdivided into short, squat rectangles, and the houses are often set far back from the street edge. Open space is generous, with most houses having a large back garden and medium-sized front garden. Space between neighbours is also reasonably generous, often around three to four metres. Houses are a mixture of one and two storey cottages, bungalows and Victorian styles. Its low density of population and dwellings is apparent in the somewhat dispersed form.



Figure 3.12 - Aerial view over Karori

Source: Love, W H, fl 1943. Aerial view over Karori, Wellington, showing the construction of coastal defence works at Wright's Hill during World War II. Pascoe, John Dobree, 1908-1972 :Photographic albums, prints and negatives. Ref: PAColl-0783-2-0291. Alexander Turnbull Library, Wellington, New Zealand. <http://beta.natlib.govt.nz/records/22814448>



Figure 3.13- Karori, suburb

Source: "Karori." 41°17'03.84"S 174°44'22.40"E. Google Earth. March 2, 2009. June 27, 2011.



Figure 3.14 - Karori, block

Source: "Karori." 41°17'14.87"S 174°44'31.78"E. Google Earth. March 2, 2009. June 27, 2011.



Figure 3.15 - Karori, houses

Source: "Karori." 41°17'16.49"S 174°44'33.37"E. Google Earth. March 2, 2009. June 27, 2011.W

Island Bay: The gridded area of Island Bay is situated on the flat land formed in the valley between two hills, forming an elongated grid. The main street runs north-south, with two minor streets running parallel on either side. The other streets run perpendicular, until they meet the sudden slopes of the hills where they trail off. Blocks are long rectangles, which are subdivided into narrow rectangles. Houses are built only a couple of metres apart from their neighbours, but are often set back from the street by a medium-sized front garden, while back gardens are generally reasonably sized, but are often displaced by backyard infill housing. The most common housing types are one-storey bungalows, cottages and Victorian villas.

68



Figure 3.16 - View over Island Bay

Source: Island Bay, Wellington, Pencarrow Head in background. Whites Aviation Ltd :Photographs. Ref: WA-65202-F. Alexander Turnbull Library, Wellington, New Zealand. <http://beta.natlib.govt.nz/records/23024449>



Figure 3.17 - Island Bay, suburb

Source: "Island Bay." 41°20'10.69"S 174°46'19.95"E. Google Earth. March 2, 2009. June 27, 2011.

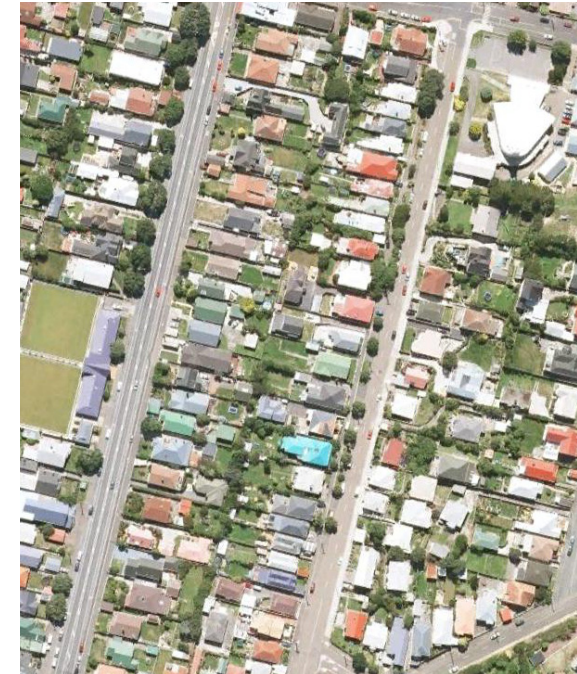

Figure 3.18 - Island Bay, block

Source: "Island Bay." 41°20'20.91"S 174°46'21.34"E. Google Earth. March 2, 2009. June 27, 2011.



Figure 3.19 - Island Bay, houses

Source: "Island Bay." 41°20'22.85"S 174°46'21.08"E. Google Earth. March 2, 2009. June 27, 2011.

Berhampore: The main streets of Berhampore run continuously north-south, while east-west streets connect between them, but often only for the length of one block. Blocks are mostly small rectangles, or larger ones that are partially penetrated by minor streets. Again, the main pattern of subdivision is long narrow lots, and houses are built closely together, at the street edge. Most have generous back gardens. There are some higher density council housing buildings that don't follow the grain of the older development. Houses are mostly one storey Victorian villas, and some cottages.

70



Figure 3.20 - View over Berhampore, looking towards Wellington Harbour

Source: Wellington, from Berhampore to Lambton Harbour. Whites Aviation Ltd :Photographs. Ref: WA-65194-F. Alexander Turnbull Library, Wellington, New Zealand. <http://beta.natlib.govt.nz/records/22685646>



Figure 3.21 - Berhampore, suburb

Source: "Berhampore" 41°19'20.84"S 174°46'33.79"E. Google Earth. March 2, 2009. June 27, 2011.



Figure 3.22 - Berhampore, block

Source: "Berhampore" 41°19'13.35"S 174°46'35.73"E. Google Earth. March 2, 2009. June 27, 2011.



Figure 3.23- Berhampore, houses

Source: "Berhampore" 41°19'13.53"S 174°46'35.16"E. Google Earth. March 2, 2009. June 27, 2011.

Newtown: Newtown's main streets run continuously from north to south, while east-west streets bisect these axes irregularly. This arrangement results in a variety of block sizes, but for the most part they are small and rectangular. These are then subdivided into small lots with narrow street frontages. Houses are very closely spaced, with less than one metre between many. Houses are set back only a couple of metres from the street edge, leaving a small front garden and reasonably sized back garden. Newtown also has some light industrial buildings, and several medium to high density social housing developments scattered throughout the detached house fabric. Housing typologies are workers' cottages, bungalows, and Victorian townhouses. The finely grained urban form illustrates Newtown's status as the highest density suburb of the ones studied.

72



Figure 3.24 - Aerial view over Newtown

Source: Aerial view of Newtown, Wellington. Hinge, Leslie, 1868-1942 :Collection of photographic prints and negatives. Ref: 1/2-034778-G. Alexander Turnbull Library, Wellington, New Zealand. <http://beta.natlib.govt.nz/records/22340956>



Figure 3.25 - Newtown, suburb

Source: "Newtown" 41°18'51.84"S 174°46'52.33"E. Google Earth. March 2, 2009. June 27, 2011.



Figure 3.26 - Newtown, block

Source: "Newtown" 41°18'57.11"S 174°47'02.92"E. Google Earth. March 2, 2009. June 27, 2011.

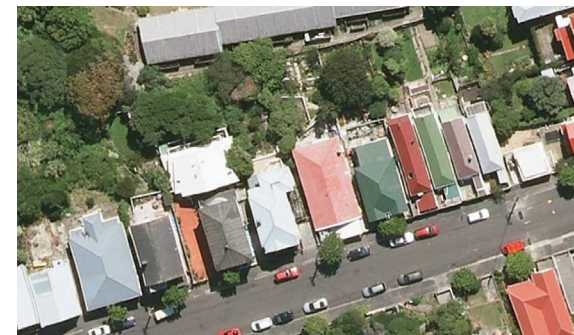

Figure 3.27 - Newtown, houses

Source: "Newtown" 41°18'57.11"S 174°47'02.92"E. Google Earth. March 2, 2009. June 27, 2011.

Lyall Bay: The Lyall Bay street grid has its dominant axes running north-south. These are bisected by minor roads in the east-west direction. The resultant blocks are quite wide, and have been subdivided into long narrow lots. The length of the lots, at least 60 metres, means that many have two houses built on them, one at the front and an infill house at the back. Many of the houses face directly onto the street edge, while others are set back up to 10 metres. Because many lots have two houses, private open space is reduced. The houses are reasonably closely spaced, with a couple of metres between neighbours. Victorian villas, cottages and bungalows make up the mostly one-storey fabric.



Figure 3.28 - View over Lyall Bay

Source: Aerial view over Lyall Bay, Kilbirnie, and Evans Bay, Wellington. Pontefract, J :Chiefly photographs of Antarctica. Ref: 1/2-098636-F. Alexander Turnbull Library, Wellington, New Zealand. <http://beta.natlib.govt.nz/records/22731110>



Figure 3.29 - Lyall Bay, suburb

Source: "Lyall Bay" 41°19'34.64"S 174°47'38.81"E. Google Earth. March 2, 2009. June 27, 2011.



Figure 3.30 - Lyall Bay, block

Source: "Lyall Bay" 41°19'40.12"S 174°47'39.60"E. Google Earth. March 2, 2009. June 27, 2011.



Figure 3.31 - Lyall Bay, houses

Source: "Lyall Bay" 41°19'39.60"S 174°47'39.97"E. Google Earth. March 2, 2009. June 27, 2011.

Kilbirnie: Kilbirnie has a linear street grid, with main streets running north to south, forming long narrow blocks, which are in turn divided into long narrow lots. Houses are built very close to the street edge, leaving long back gardens, and small front gardens. Neighbours are very close, with around one metre between houses. Most houses are one storey, with a mixture of Victorian and cottage styles. The high density dwelling ratio is visible in the urban form.



Figure 3.32 -View over Kilbirnie

Source: Aerial view of Lyall Bay, Wellington. Negatives of the Evening Post newspaper. Ref: 1/4-048800-G. Alexander Turnbull Library, Wellington, New Zealand. <http://beta.natlib.govt.nz/records/23046068>



Figure 3.33 - Kilbirnie, suburb

Source: "Kilbirnie" 41°19'16.06"S 174°48'02.96"E. Google Earth. March 2, 2009. June 27, 2011.



Figure 3.34 - Kilbirnie, block

Source: "Kilbirnie" 1°19'12.54"S 174°48'03.33"E. Google Earth. March 2, 2009. June 27, 2011.



Figure 3.35 - Kilbirnie, houses

Source: "Kilbirnie" 41°19'12.11"S 174°48'03.07"E. Google Earth. March 2, 2009. June 27, 2011.

Miramar: Miramar's street pattern is the amalgamation of two types of grids. One is linear, made up of equal-sized rectangular blocks. The other is radial, resulting in wedge or trapezoidal-shaped blocks of a similar size to the rectangular blocks. The blocks are subdivided into narrow rectangular lots, with the short edge facing the street. A large proportion of the lots have a house at the front and an infill house at the back, meaning that a typical block can have four houses through its width. This limits room for personal outdoor space; most of the houses have small private gardens. Houses are set quite far back from the street edge, and often have garages facing onto the street. One-storey cottages dominate the suburb.

78



Figure 3.36 - View over Miramar

Source: Aerial view of the suburb of Miramar, Wellington. Original photographic prints and postcards from file print collection, Box 14. Ref: PAColl-6585-34. Alexander Turnbull Library, Wellington, New Zealand. <http://beta.natlib.govt.nz/records/22846650>



Figure 3.37 - Miramar, suburb

Source: "Miramar" 41°19'02.26"S 174°49'01.49"E. Google Earth. March 2, 2009. June 27, 2011.



Figure 3.38 - Miramar, block

Source: "Miramar" 41°19'11.31"S 174°49'02.95"E. Google Earth. March 2, 2009. June 27, 2011.



Figure 3.39 - Miramar, houses

Source: "Miramar" 41°19'11.64"S 174°49'03.70"E. Google Earth. March 2, 2009. June 27, 2011.

Seatoun: Seatoun has a very regular linear grid with blocks that are almost square in proportion. The streets run north-east to south-west, and north-west to south-east. All the streets run continuously through the suburb. The blocks are subdivided into long, narrow lots, with the shortest edge facing the street. The houses are generally built close to the street edge, with long back gardens, while neighbouring houses are closely spaced. The main typology is the one-storey cottage, but there are also many large contemporary houses.



Figure 3.40 - Aerial view of Seatoun

Seatoun, Wellington. Whites Aviation Ltd :Photographs. Ref: WA-61169-F. Alexander Turnbull Library, Wellington, New Zealand.
<http://beta.natlib.govt.nz/records/22330784>



Figure 3.41 - Seatoun, suburb

Source: "Seatoun" 41°19'28.75"S 174°49'59.47"E. Google Earth. March 2, 2009. June 27, 2011.



Figure 3.42 - Seatoun, block

Source: "Seatoun" 41°19'37.07"S 174°50'00.54"E. Google Earth. March 2, 2009. June 27, 2011.



Figure 3.43 - Seatoun, houses

Source: "Seatoun" 41°19'37.08"S 174°50'00.44"E. Google Earth. March 2, 2009. June 27, 2011.

Similarities and differences between grid forms:

The street grids differ vastly between the suburbs. Some are far more regular than others, some are elongated, and some are wide. The resulting blocks are varied in size and shape, while most are long and thin, others are wide and partially penetrated by roads.

When each suburb was broken down to the level of individual house and lot, it became apparent that this basic element was almost identical across all of them (figure 3.44). The rectilinear lot with narrow street frontage is the common element found across all of the grid plans, and will be used as the starting point for the design of a medium-density residential development.

Figure 3.44 - Suburbs compared (street network, street grid, block and subdivision, footprints, house placement)

Source: Author's own image

KARORI

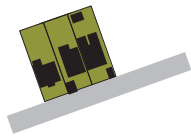
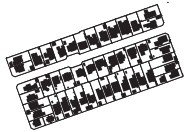
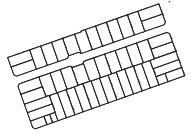
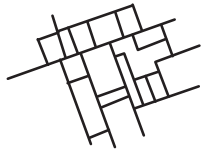

ISLAND BAY

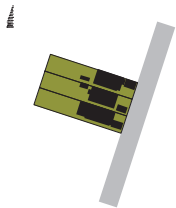
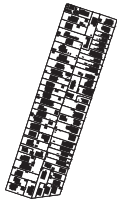
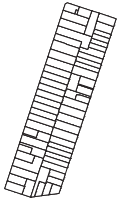

BERHAMPORE

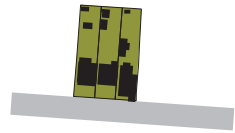
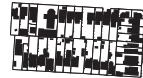
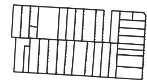

NEWTOWN

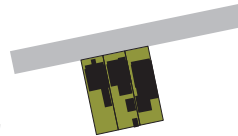
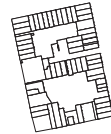

LYALL BAY

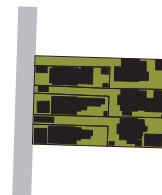

KILBIRNIE

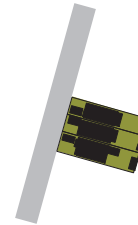
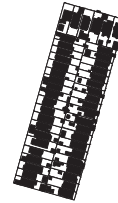
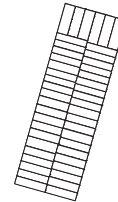

MIRAMAR

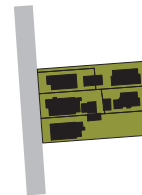
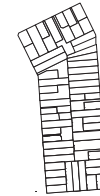

SEATOUN

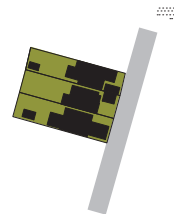
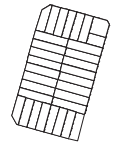

STREET NETWORK

STREET GRID

BLOCK AND SUBDIVISION

FOOTPRINTS

HOUSE PLACEMENT

Reasons for locating intensification within grids:

Medium-density residential development in Wellington is well suited to those areas that are on flat land, with a gridded street plan and regular block subdivision. These areas are the ideal for this type of development for the following reasons:

Flat land: Building on flat land provides ease of construction, site access, and material delivery. The excessive costs of massive earth removals and retaining walls are avoided.

Close to suburban centres: Early suburbs developed with a local main street of shops and amenities located on the flat land. Developing medium-density housing around these areas will help to support local businesses, and stimulate a vibrant community centre, while providing convenience for residents.

Well served by public transport: Wellington's bus network runs through the main streets of these suburbs, which are always located within the flat, gridded parts. By locating housing conveniently for public transport, vehicle dependency is reduced, and public transport efficiency is increased.

84 High levels of connectivity: There are few cul-de-sacs or dead-end roads in grid plans; they are the most highly connected form of street network, which increases choices and ease of mobility for pedestrians and vehicles.

Replicable conditions: This is the most important factor in selecting the grid plans as the ideal locations for medium-density housing. Although the overall structure of the gridded plans varies from suburb to suburb, the base conditions are the same, as seen in the study above. Therefore a guiding set of principles for the development of medium-density housing can be developed and applied to multiple sites across Wellington.

Although each suburb has its own unique gridded street network, several over-arching aspects of the nature of the grid itself will allow similar types of development to take place within each suburb.

Newtown

Newtown was selected as the case-study suburb because it has a large projected increase in population of nearly 27% by 2030. It is close to the central city, and is well connected by multiple regular bus services. It has a very strong local town centre with a supermarket, local retailers, cafes, restaurants, and community facilities. There are several primary schools in Newtown itself, and more primary schools, intermediates, and high schools in the suburbs immediately adjacent. There is a strong local employment base at the Wellington Hospital, with many employees choosing to live in Newtown for convenience while on call. Newtown has many desirable aspects of a compact, walkable city advocated by the urban theorists discussed in the literature review.

Newtown's urban form has a gridded street plan with the main axes running north-south, and rectangular blocks that are subdivided into long narrow lots. The main house typologies are cottages, bungalows and Victorian villas and townhouses. There are also several medium to high density council housing blocks that are out of scale with the finely grained historical development.

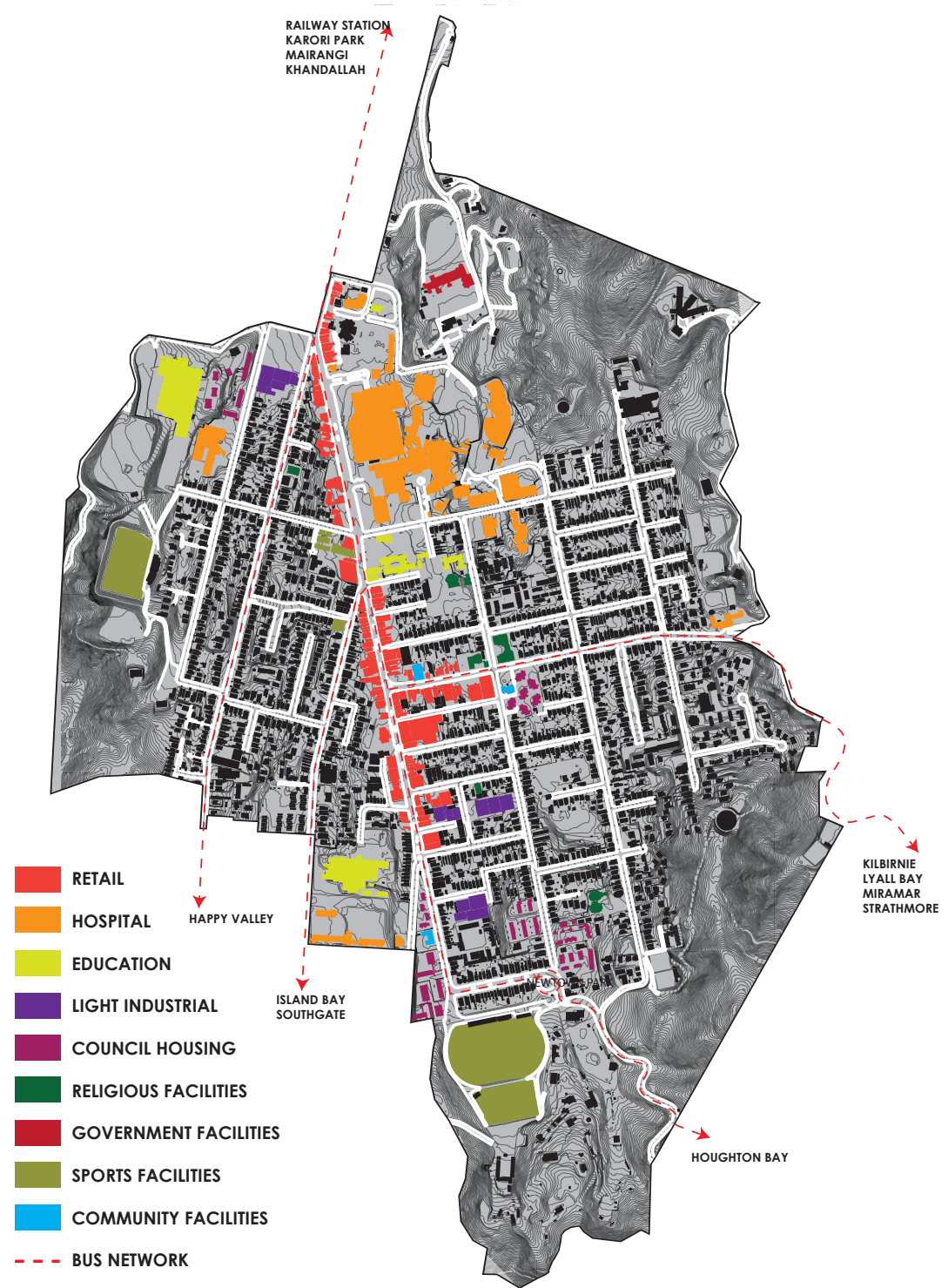

Early development

Newtown was the first suburb outside of the central city to be developed by early settlers. The blocks were set up as one acre farms, and sold off to owners in England (Irvine-Smith 1948). As the settler population grew, the demand for houses increased also, and Newtown's one acre blocks were slowly divided by new streets, creating smaller blocks, which in turn were divided into narrow residential lots. This pattern of development has resulted in an extremely finely grained urban texture. Houses were built so closely together that they form a seemingly continuous street elevation, framing the public sphere and protecting private open space.

Newtown's current urban form is finely grained, with small lots and building footprints creating a dense, consistent fabric (figure 3.48).

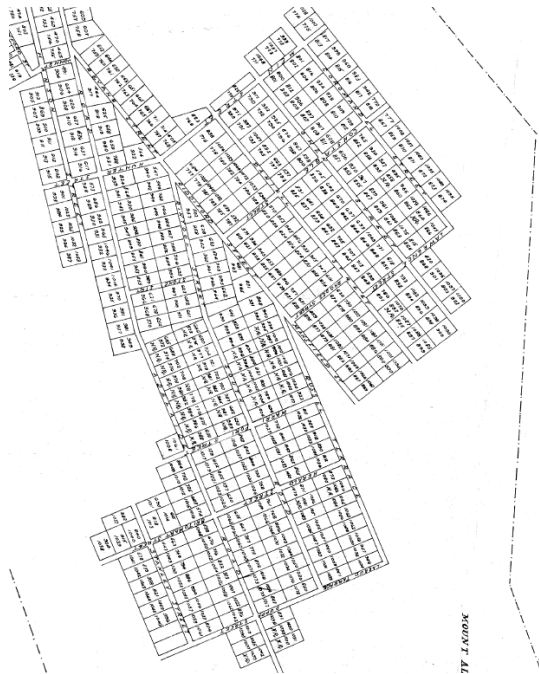

Figure 3.46 - Detail showing Newtown, plan of the town of Wellington Port Nicholson, 14 August 1840
Source: Wellington City Archives

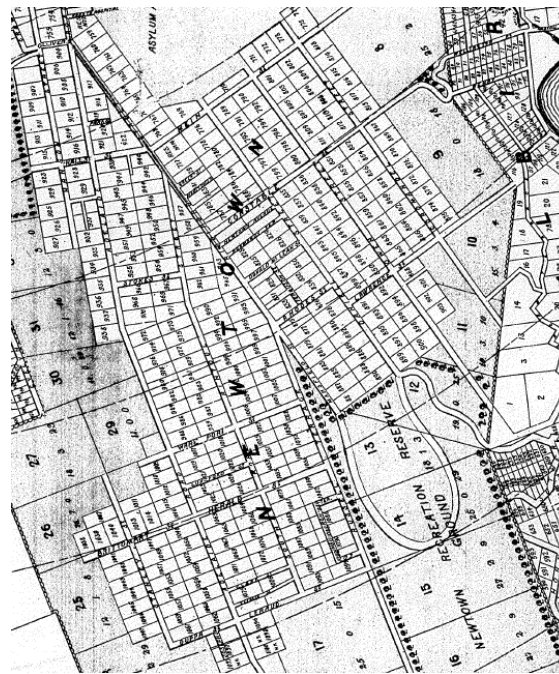

Figure 3.47- Detail showing Newtown, plan of the city of Wellington and surrounding districts, 1880
Source: Wellington City Archives



Figure 3.48 - Urban grain sketch
Source: Author's own image

The Street

Within Newtown, one street was selected for closer examination and to provide a specific site to test the design of medium-density infill. Roy Street is located at the very southern end of Newtown. It was selected for closer study, and for locating the design case study because it has a consistent subdivision pattern and a strong sense of local identity. It is representative of the suburban sites studied as it has a regular block form consistent subdivision with rectilinear lots, and closely-knit houses that are set back minimally from the street edge.

Block

Roy Street did not exist in Newtown's original street plan. It was formed in 1905 when developer Archibald Hall ran a street through the end of southernmost block in Newtown, bisecting it in the east-west direction (Irvine-Smith 1948). The street formed one block backing on to Newtown Park that was only one residential lot deep, while the other side of the street backs on to the rest of the block which has subsequently been subdivided in a somewhat haphazard fashion.

Subdivision

The smaller blocks were then divided up into approximately equal-sized lots, with the length of about 36 metres running north-south, and a narrow street frontage of about 6.5 metres.

Houses

Many of the houses were built speculatively by the developers Crighton and Parke (1906), and sold off to individual owners. The houses are placed close to the street edge and each other.

Built and natural character

Street edge

All the houses follow a consistent set-back line between 2.5 and 3.5 metres along both sides of the street. Each house has a fence separating it from the street, the most common type being white picket fence, but there are also solid concrete fences and cast-iron railings. All the fences run along the same line, forming a continuous edge to the footpath. There is a clear distinction between public space (the street), transition space (between the gate and the front door), and private space (the house). The minimal setbacks frame the street and provide visual interest and texture.

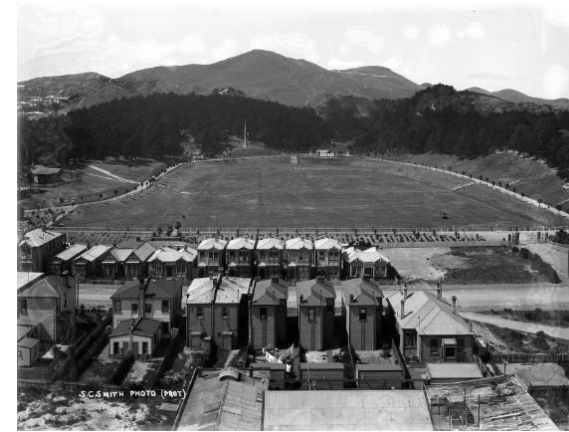

Figure 3.49 - Roy Street 1909

Newtown, Wellington, looking north over Roy Street and Newtown Park to Mount Alfred. Smith, Sydney Charles, 1888-1972 :Photographs of New Zealand. Ref: 1/1-019674-G. Alexander Turnbull Library, Wellington, New Zealand. <http://beta.natlib.govt.nz/records/23155655>



Figure 3.50 - Roy Street circa 1920

Source: Houses with Newtown Park in the background. Smith, Sydney Charles, 1888-1972 :Photographs of New Zealand. Ref: 1/2-048925-G. Alexander Turnbull Library, Wellington, New Zealand. <http://beta.natlib.govt.nz/records/22839892>

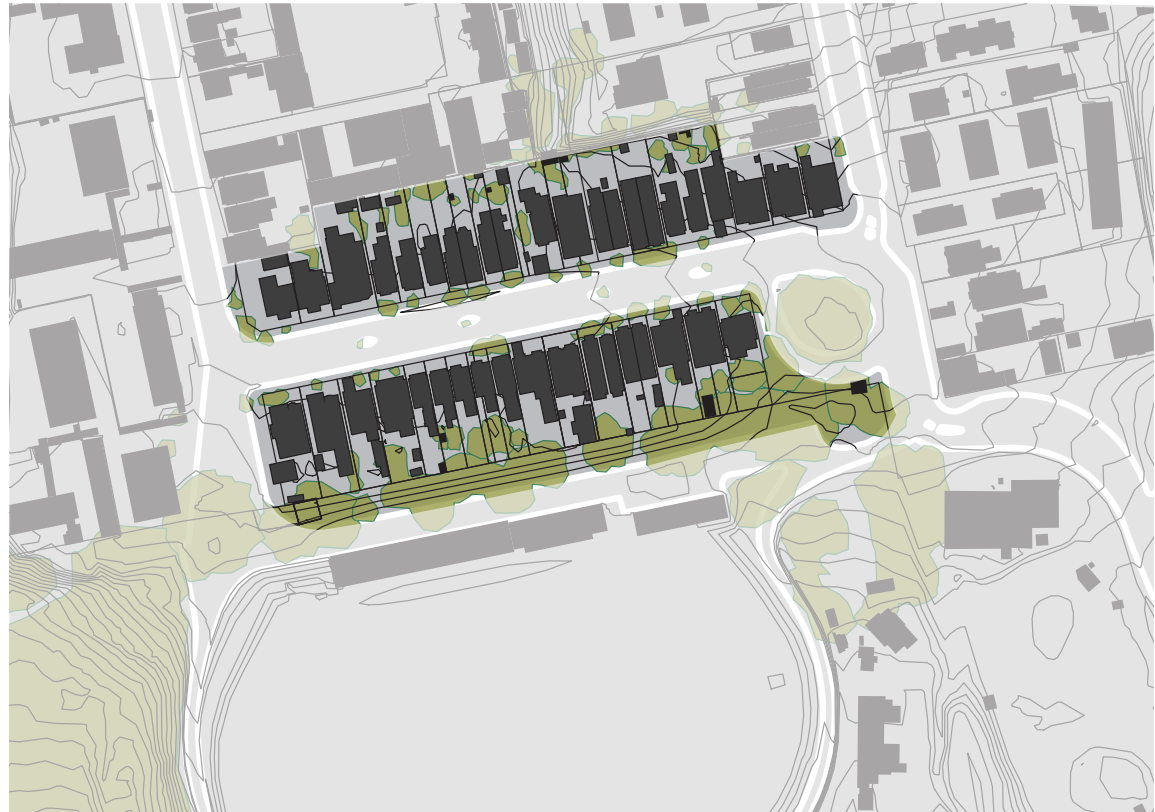

Figure 3.51 - Roy Street existing site plan
Source: Author's own image

Housing typologies/built tradition

In the street the two main housing types are two-storey Victorian townhouses and one-storey bungalows. The individual Victorian townhouses were built between 1905 and 1908, when the street was first developed; a set of five on the south side of the street were all built to the same plan. There are also several semi-detached two-storey townhouses on the north side of the street. The bungalows were built later, between 1916 and 1926, and their lots are twice as wide as the townhouse lots (figure 3.52). The closely-spaced two storey houses form a frame for the street, defining the space. The street's unique character is derived from the variation within the repetition of the Victorian form. Repetition establishes an easily understandable pattern, while variation provides visual interest.

Figure 3.54 - (opposite page) Roy Street panorama

Source: Author's own image

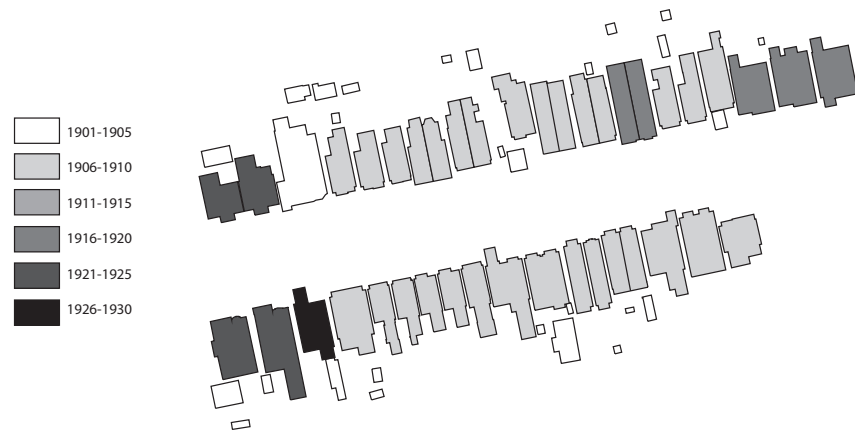

Figure 3.52 - Roy Street house ages

Source: Author's own image

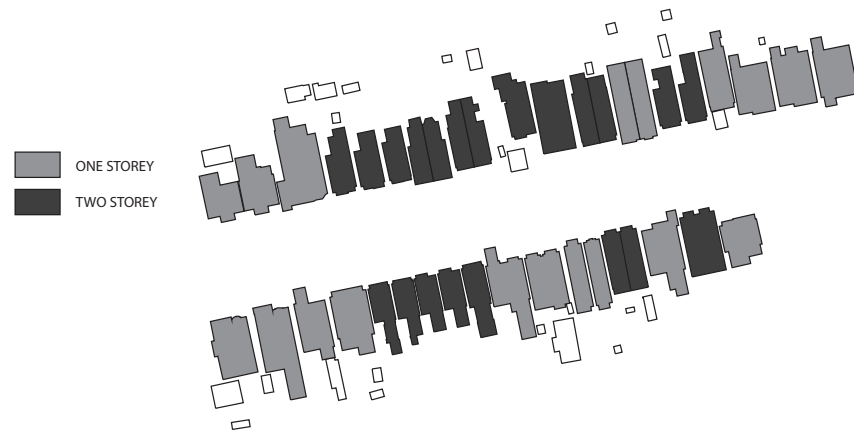

Figure 3.53 - Roy Street house storeys

Source: Author's own image



Green space

The street sits at the edge of the town belt, so is surrounded on three sides by green bush and trees covering the hills (figure 3.55). Directly behind it is Newtown Park, and to the east is the Wellington Zoo. On a closer scale, the street itself has a unique character in that it is highly planted. Large deciduous trees line the footpath, and are also planted within the road's median strip (figure 3.56). The roots of these trees have started to deform and crack the concrete footpath. Unlike most native trees, these trees have leaves, blossoms or bare branches, changing with the seasons. The small gardens in front of each house have different forms of planting. Some have large trees that almost entirely block the house from view. Others have neatly trimmed hedges and well-kept flower pots, while some have rambling trailers that creep over fences into the street (figure 3.57). The two scales of natural growth; the surrounding town belt and the immediate trees; contribute to a very individual character and sense of place.

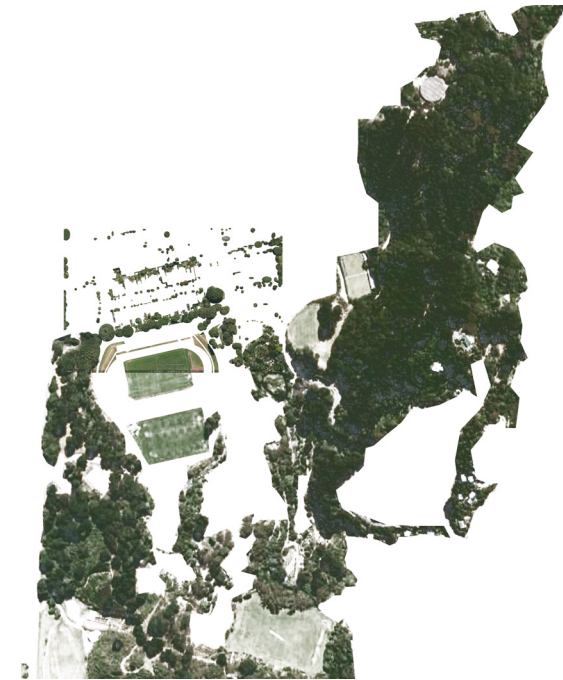

Figure 3.55 - Town belt surrounding Roy Street
Source: Author's own image



Figure 3.56 - Roy Street trees
Source: Author's own image



Figures 3.57 - Roy Street trees and greenery
Source: Author's own photos

Victorian townhouse

The Victorian townhouse is studied as an initial building block for the medium-density design. By keeping the same plan proportions the new development will keep continuity with the urban grain.

Organisation

The townhouses are organised extremely efficiently, with an economic floor plan and circulation. The main features lacking in these townhouse plans, and many other similar ones, are proper orientation for sun access in main living spaces, and connections to external living spaces, both aspects identified in the literature review as crucial for design quality and liveability.

Floor plan

The townhouse plan is a typical one-bay plan with a front living room facing the street, dining room behind, and small kitchen at the back to the left, which provides access to the back garden. The first floor has four bedrooms, two at the front and two at the back, and a bathroom. The same plan is repeated several times in Roy Street. Each room is completely separated from the next by walls; there is no open planning or spatial flow. This was appropriate at the time in which they were built, but demand has changed for more informal open plans.

Circulation

Ground floor circulation is linear; a corridor runs down the length of one side of the house with access to the rooms off it. Stairs offer access to the upper level, with room access off a central landing (figure 3.59). The circulation spaces are narrow, with limited natural light, but they are efficient in size and arrangement. By locating the circulation to the left of the house, adaptations are able to be made to the living spaces without relocating the stairs.

Public outdoor space

The front garden acts as a buffer between the house and the street. It is about 2.7 metres from the front gate to the entrance porch, and this area generally has a paved path directly to the porch, and bushes or trees in the rest of the garden. The planting can act as a screening device by filtering views into the front living room.

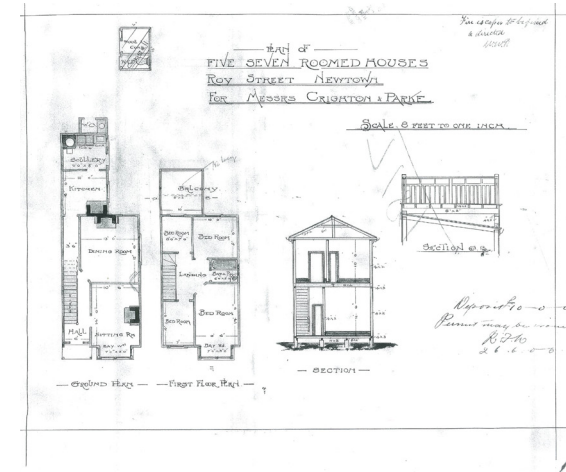

Figure 3.58 - Plan of five seven roomed houses, Roy Street, Newtown, for Messrs Crighton and Parke

Source: Wellington City Archives

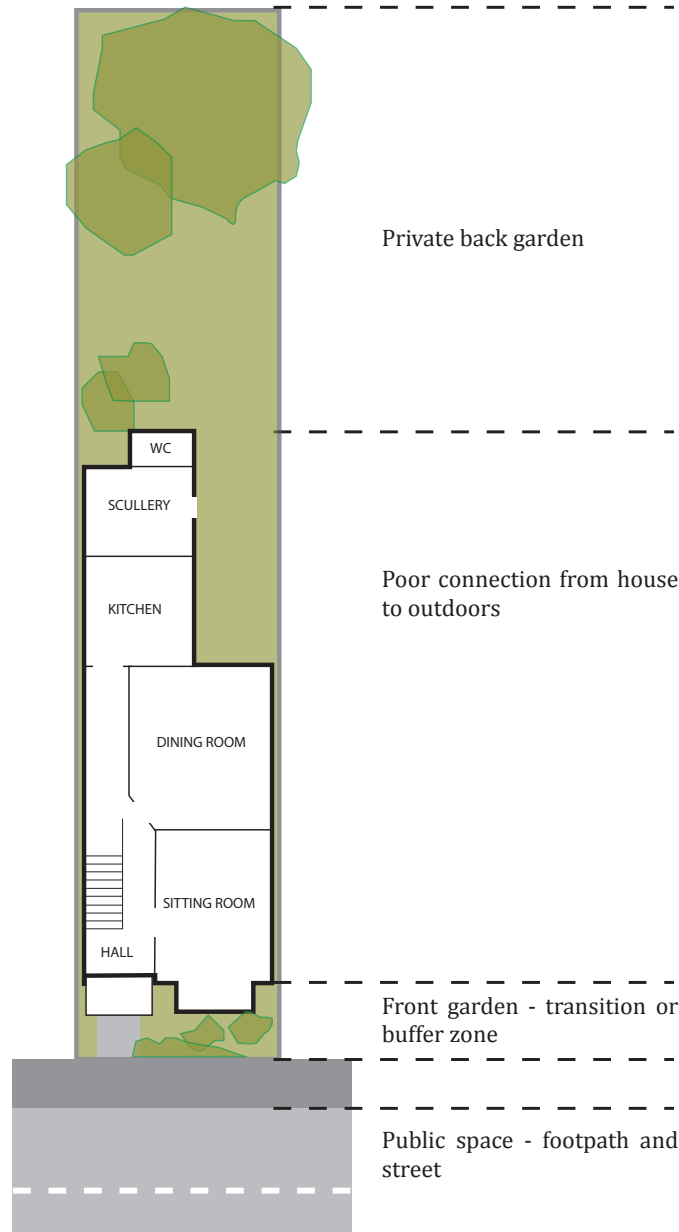
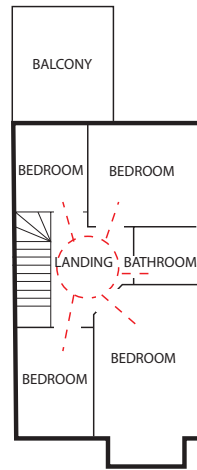
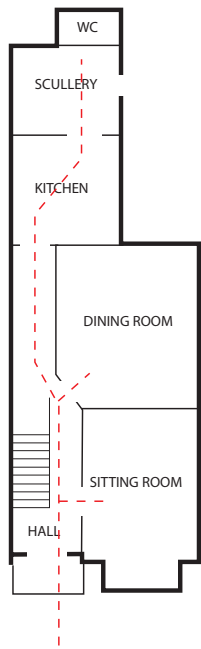

Figure 3.59 - Victorian townhouse plan and circulation

Source: Author's own image

Figure 3.60- Victorian townhouse connection to outdoor space

Source: Author's own image

Private outdoor space

Each house has a large back garden (figure 3.60) that is used by residents in different ways. They have garden sheds, paved areas, shading devices, flower and vegetable gardens, and outdoor furniture. The connection between internal and external living is not strong (figure 3.60). The garden is typically accessed through the kitchen; there is no extension of the internal living spaces to the outside. The living room is at the opposite end of the house, with no outdoor space provided. Depending on the orientation, the back garden may be in shade from the house.

Orientation for sun

The same plan is distributed on both sides of the street. On the north-facing side of the street the plan works well as the front living room receives sun for much of the day. On the south facing side the living room receives absolutely no sun. Figure 3.61 illustrates the differing light qualities and sunlight access within the same plan, which changes depending on orientation. This plan doesn't adequately respond to site conditions.

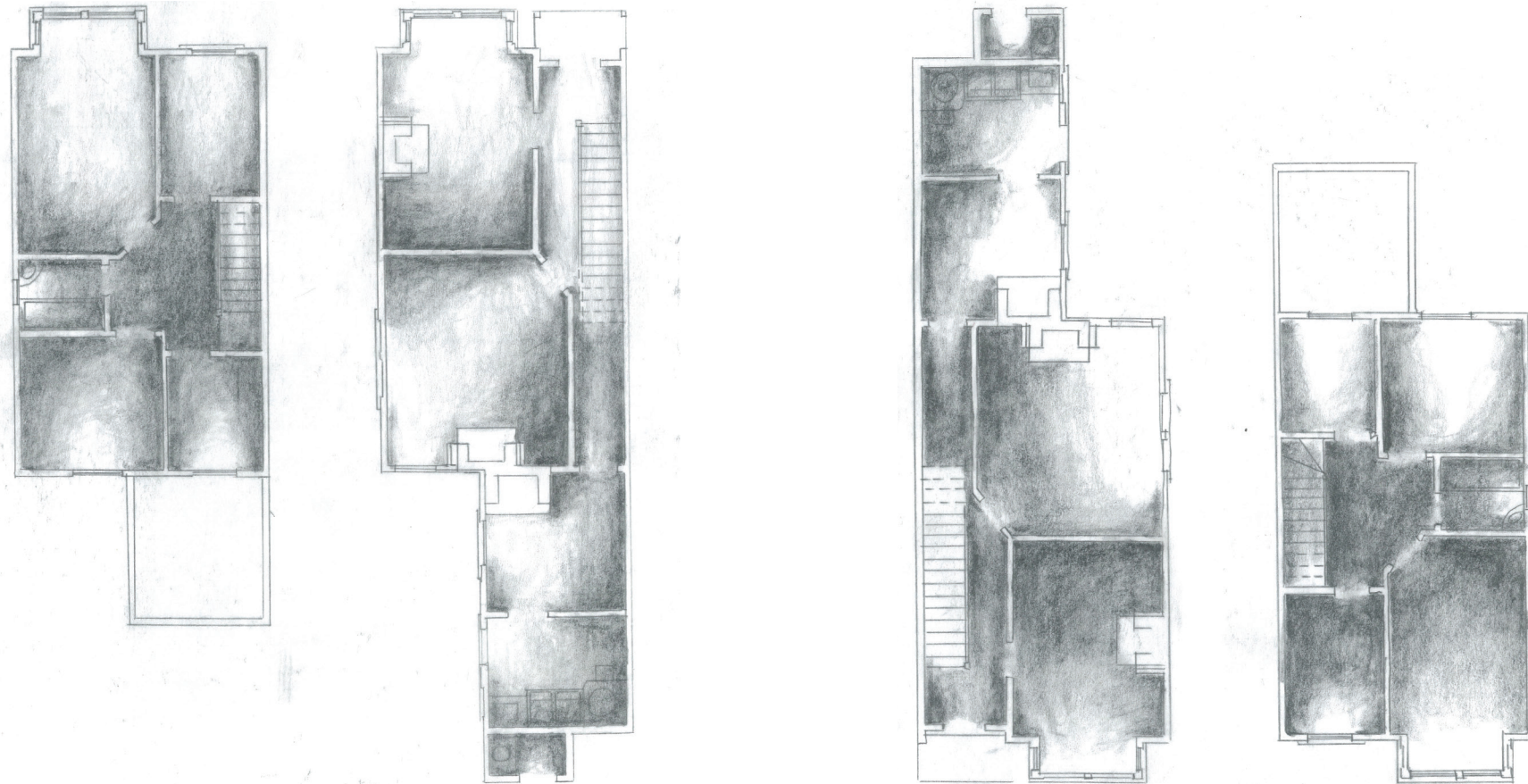

Figure 3.61 - Sunlight analysis: sketch of sunlight for plan when oriented north (left), and south (right)

Source: Authors own image



What can be learned from the Victorian townhouse

Flexibility in plan and section

The Victorian townhouse plan is found across Wellington, but also in other cities in New Zealand, Australia, England, and North America. It has endured because its internal layout is extremely flexible. Some of the examples in Roy Street have been adapted into separate flats, while one is a bed and breakfast. In England they have a rich history of being turned into offices and even schools. The location of circulation and set-out of rooms has proved to be very flexible and endlessly adaptable.

Poor orientation of living areas to sun

The houses were not designed with the climatic conditions of the site in mind. The same plan is repeated, whether facing north or south, instead of being adapted to better suit the site's orientation. For a pleasant living space and for passive environmental reasons, effective sun orientation is important.

Poor connections to private outdoor space

The houses all have large back gardens, yet there is no connection to internal spaces. New Zealanders are used to outdoor living, and well-connected indoor and outdoor spaces are highly desired by most home-owners.

Part B - Design

Brief: Medium-density housing

Aims

The aims of the medium-density housing design are: to respond to site conditions of sun and street orientation; to design flexible, adaptable dwellings that have capacity for change; to provide a variety of dwelling types and sizes in order to increase choice for demographic groups; and to integrate the design successfully into its context.

Programme

The dwellings all require a principal living area, dining room and kitchen, bedrooms, a bathroom and laundry, storage, and private outdoor space.

Each dwelling will have the attributes identified in the literature review as desirable and lacking in many new houses, including: ground floor access from the street; large, flexible rooms; efficient circulation; private outdoor space that is well integrated into living spaces; and living and outdoor spaces well-oriented for sun exposure.

102

The next step in the design case-study is to apply what has been learnt about the grid plan, accommodating different demographic groups, and the street context, into a design for medium-density housing.

Two sites within Roy Street were chosen; one facing north and one facing south. The north facing site involves the amalgamation of four lots at the left-hand end of the street. The houses currently on the site are one-storey bungalows. On the other side of the street at the opposite end another set of four lots with three bungalows and a small cottage will be amalgamated. The bungalow is a lower-density typology than the townhouse; its lot is twice as wide as the townhouse's. Therefore by replacing those with a medium-density unit based on the proportions of the Victorian townhouse the density on the particular site can be more than doubled.

Developing on the grid plan

The common elements of the grid plans studied are: highly connected street networks, perpendicular streets, consistent scale of subdivision, narrow lot size and proportion, houses placed close together, houses facing the street, and private open space at the back of lots behind the house. The design will incorporate and respond to these urban form elements in order to fit in with the existing morphology.

*Site planning**Micro subdivision*

As evidenced before, the urban grain of Newtown and the block developed as a slow process of increasingly fine levels of subdivision. The design of medium-density housing takes this a step further; the north facing site is increased from four lots to 10, while the south facing site is increased from four lots to eight (figure 3.62). The grain of the block is refined further. There is also an element of vertical subdivision, as the separate units start to overlap and interweave on the upper floors.

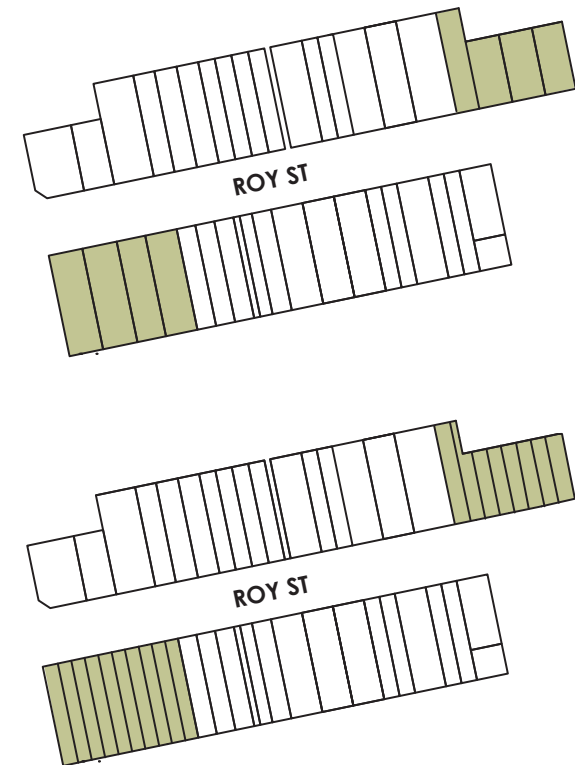

Figure 3.62 - Subdivision pattern before and after
Source: Authors own image

Car-parking

The dominant form of car-parking is on-street. Cars are parked alongside the footpath, and in the median strip. Because the dwelling density is increased, ostensibly the amount of cars will increase and space will need to be provided for them. A range of car parking options were explored:

Individual internal garage: It was decided that street-front garages could not be integrated into the streetscape because the existing houses all have very strong public frontages, and introducing garages would ruin this continuity and create blank street-level facades.

Basement: Basement car-parking was considered but deemed to be too expensive and providing internal access to the houses would have over-complicated the plans.

The solution chosen for the north-facing site was lane parking behind the houses. More parks are also created by removing the bungalows with on-street garages. The south-facing site has a shallower plot so lane parking was not possible. One of the houses for removal has a garage in front, so removing this creates one more park on the street. More spaces are also created by removing the kerb shoulder (figure 3.63).

This car-parking solution is site-specific, rather than universal, so development on other sites will need to be tailored to the local conditions.



Figure 3.63 - Roy Street car parking plan
Source: Authors own image



Plan - responding to sun and grid orientation

Planning for sun orientation and connection to outdoor space

The lesson learned from the Victorian example is that it isn't suitable to place the same plan on any site regardless of orientation. Therefore two sets of plans should be developed; one for the north-facing side of the street, and one for the south-facing side of the street.

First a schematic study was undertaken of the rooms needed and their organisation. Then the placement of the rooms was assessed in relation to how much they needed to be exposed to the sun. Orientation to sun is important for passive heating and daylighting, and pleasant living spaces.

The most important space for sun access was the living room, followed by dining. Bedrooms do not require sun exposure, as they are mostly occupied at night. The kitchen needs natural light and ventilation, but needs to be protected from late afternoon sun coming from the west to avoid excessive heat gain while cooking. It was decided that it wasn't necessary for bathrooms to have windows, and making them internal greatly freed up planning. Based on these assessments different configurations were tested. There needed to be a balance of efficient planning and pleasant living spaces. Appendix A (pg. 180) contains some of the design process images illustrating development of the plans.

Figure 3.64 - (opposite page) Roy Street proposed site plan

Source: Authors own image

North-facing:

Here the historical order of living spaces on the ground floor and bedrooms above has been reversed. North facing living spaces on the ground floor can't have direct access to a large sunny outdoor area if they are at the front of the house because this would disrupt the minimal setback line that is currently continuous along the street. The living space can't be moved to the back of the house because, although it would then have direct access to the back garden, it would receive no sun at all, and the immediate garden itself would be in shade for much of the day (figure 3.65).

Two types of units were developed, using the original Victorian townhouse plan as a starting point. Each ground floor is identical, with a room at the front, designated as a 'flexible' room, and a bedroom at the back, with a corridor from the front door through to the back of the house for back garden access. There is a bathroom and laundry between the two rooms. All the dwellings have toilets separated from the bathroom (figure 3.66).

The smaller unit, of one or two bedrooms plus a flexible room, has an open plan living, kitchen and dining area on the first floor. The kitchen is placed at the back so that it isn't exposed to afternoon sun, while the open planning makes it flexible for positioning of dining and living furniture, although it would be assumed that the main living area would be at the front of the room towards the north-facing windows. Each unit has a semi-covered balcony (figure 3.67).

The larger unit has three or four bedrooms and a flexible room. The first floor has up to three bedrooms, and a bathroom (figures 3.66 and 3.67). It then opens up on the second floor, overlapping the smaller units below, into large open plan living spaces and a large roof terrace. The kitchen and dining areas are along the back, with a separate living space at the front, forming a sheltered courtyard between them. The two internal spaces are linked by a wide hallway that can be used in multiple ways (figure 3.68). By creating a courtyard all the living spaces will receive north sun, while the living room is exposed to west sun also. All the living spaces can be opened up to fully integrate spatially with the outdoor terrace.

108

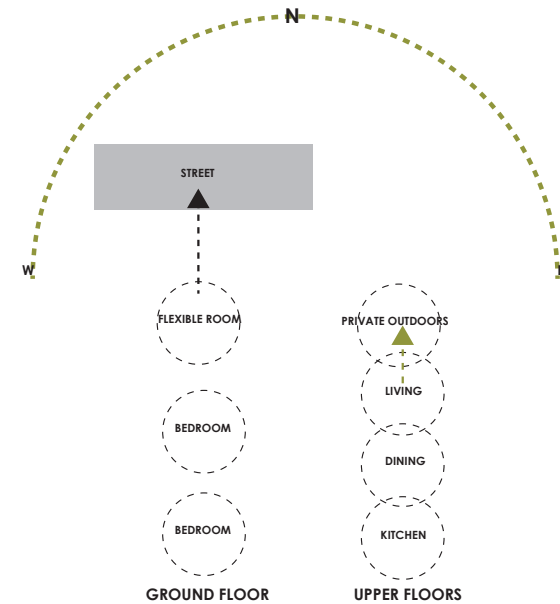

Figure 3.65 - Spatial organisation for orientation to street and sun on north-facing site

Source: Authors own image

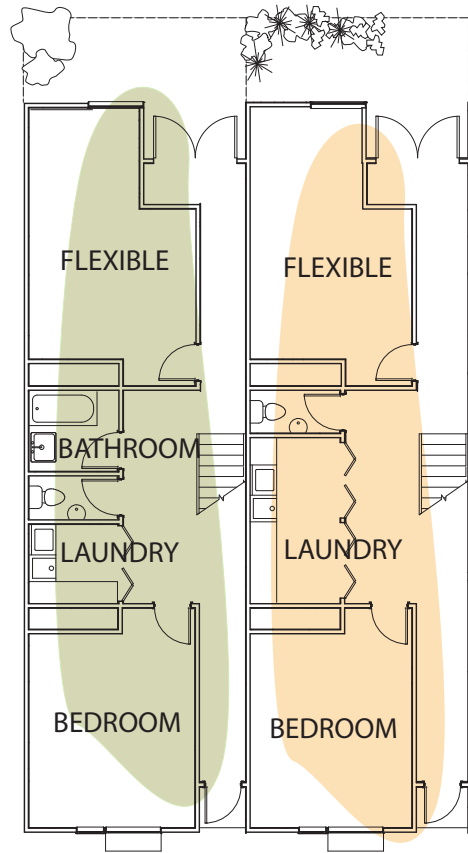

Figure 3.66 - Typical ground floor plan showing two units, small (left), large (right)
Source: Authors own image

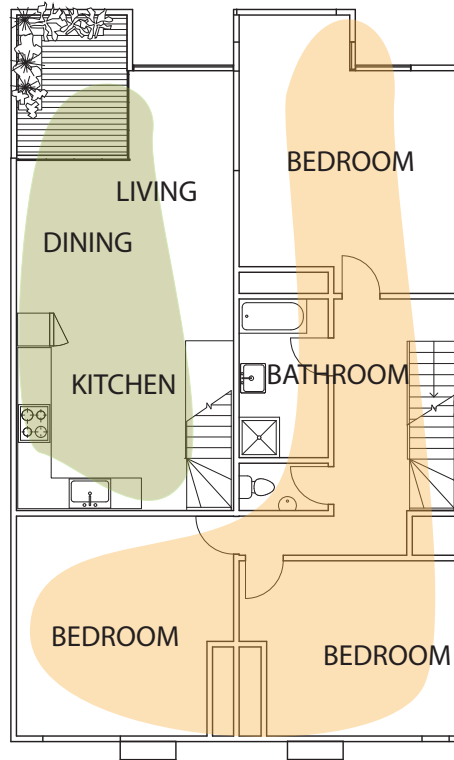

Figure 3.67 - Typical first floor plan showing two units, small (left), large (right)
Source: Authors own image

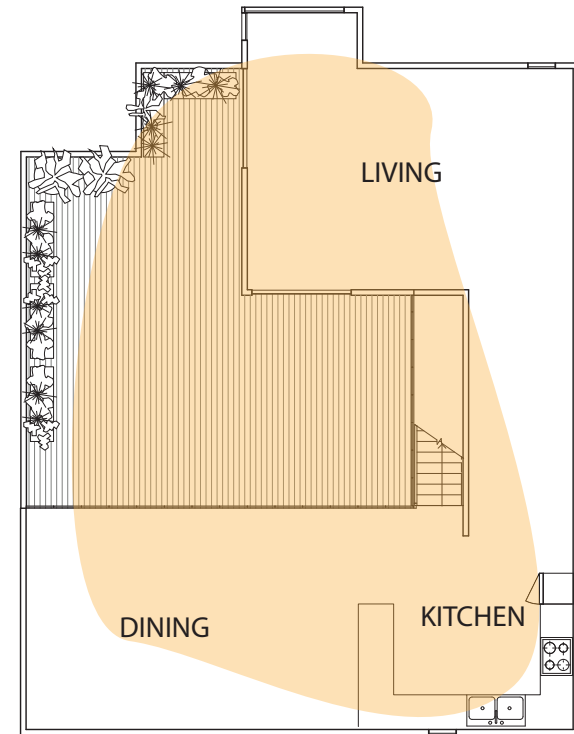

Figure 3.68 - Typical second floor plan showing one unit, large
Source: Authors own image

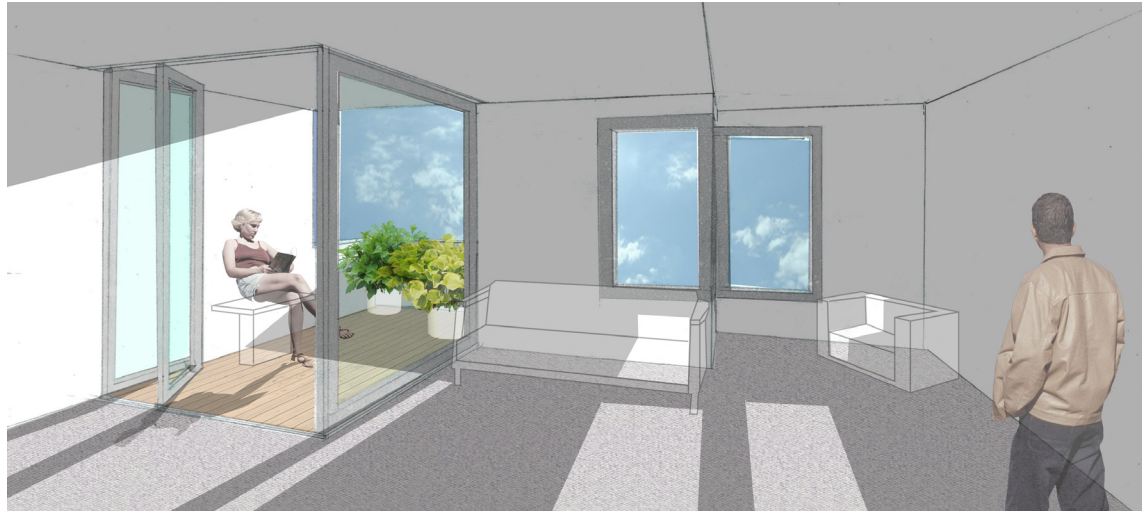

Figure 3.69 - Typical living area of small unit
Source: Authors own image

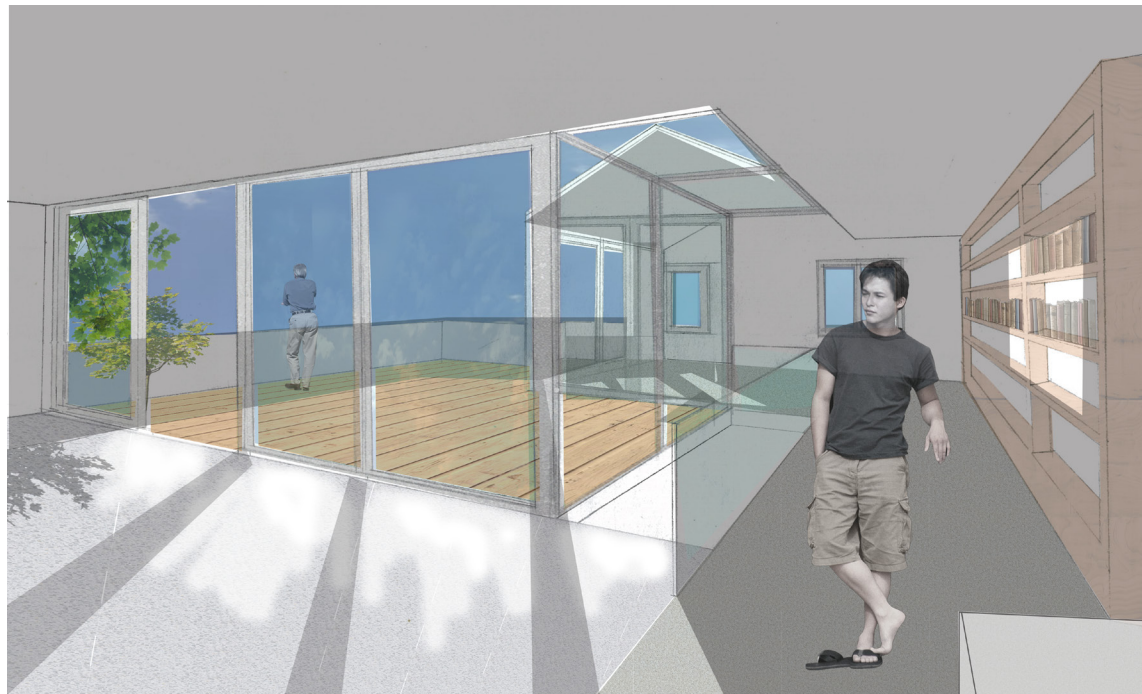

Figure 3.71 - (opposite page) Typical terrace and courtyard area of large unit
Source: Authors own image

Figure 3.70 - Typical living and dining area of large unit, looking across terrace
Source: Authors own image

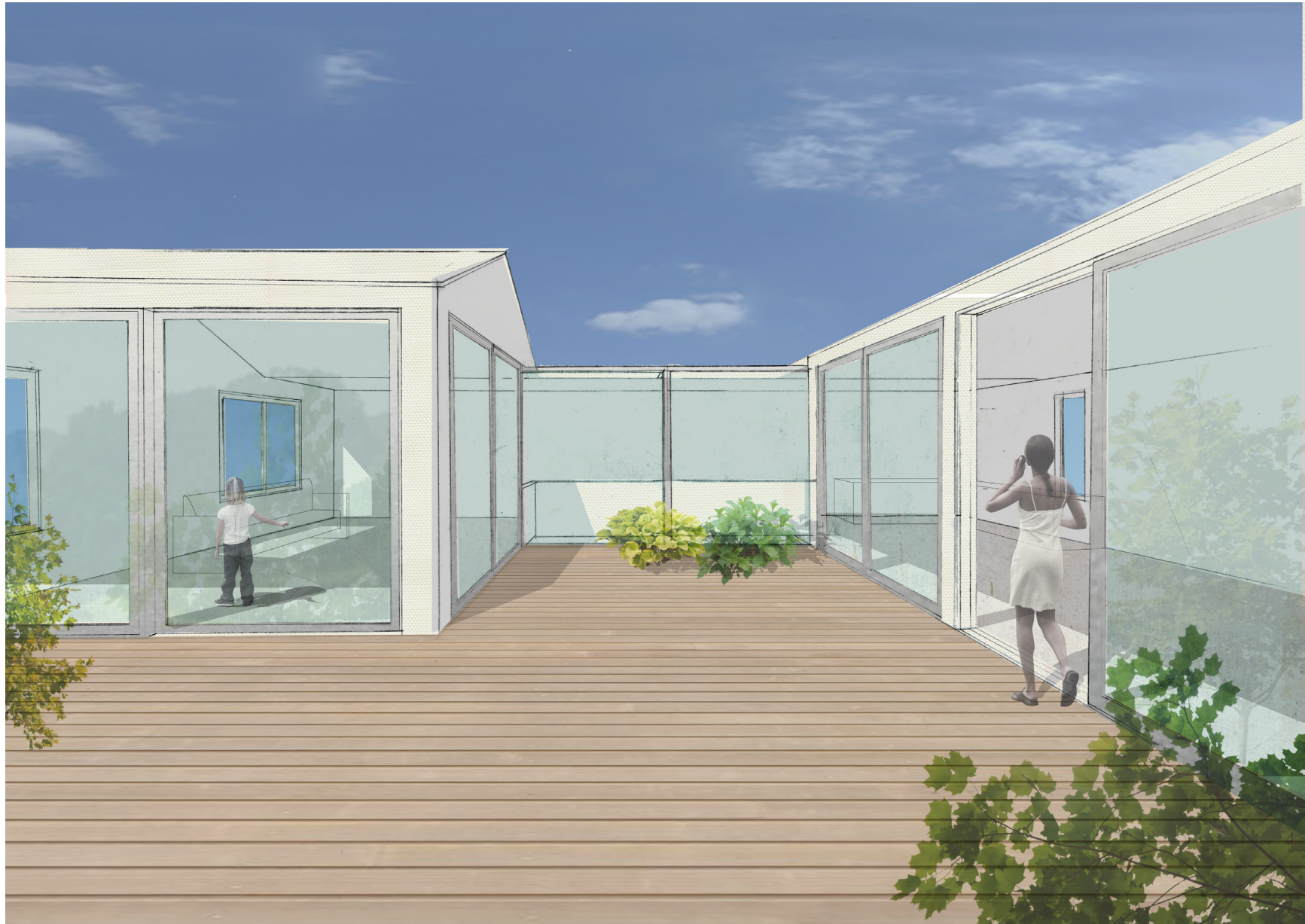



Figure 3.72 - Ground floor plan
Source: Authors own image

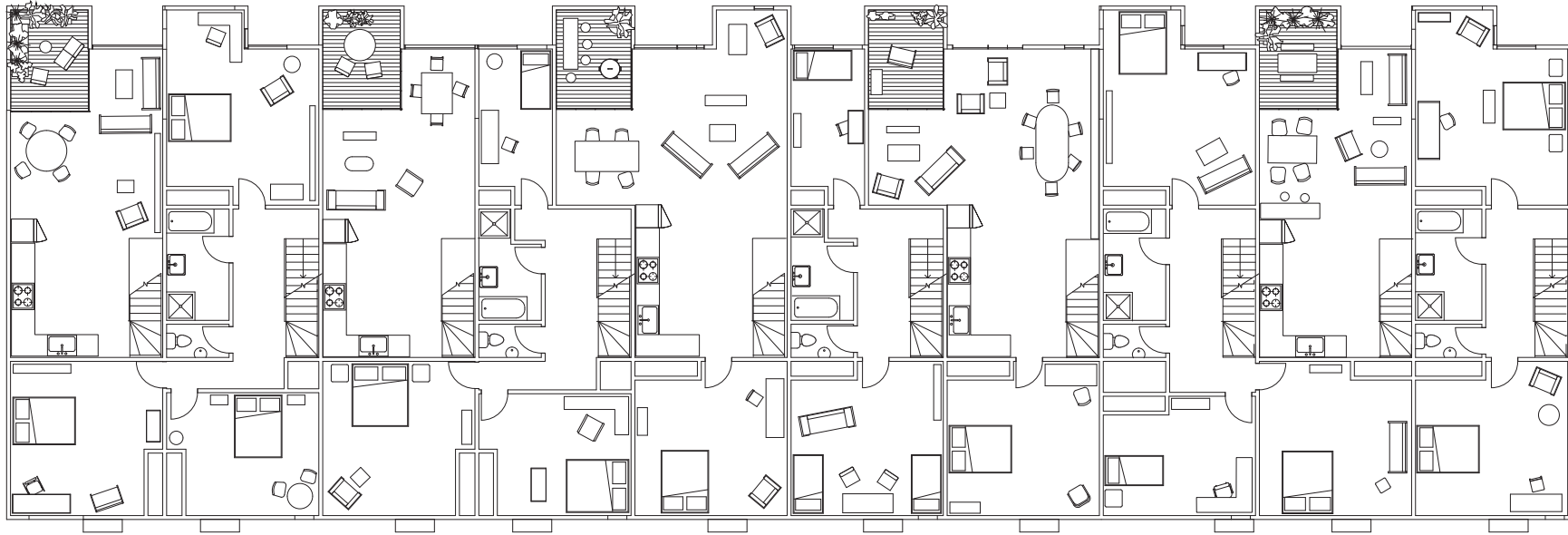

Figure 3.73 - First floor plan
Source: Authors own image

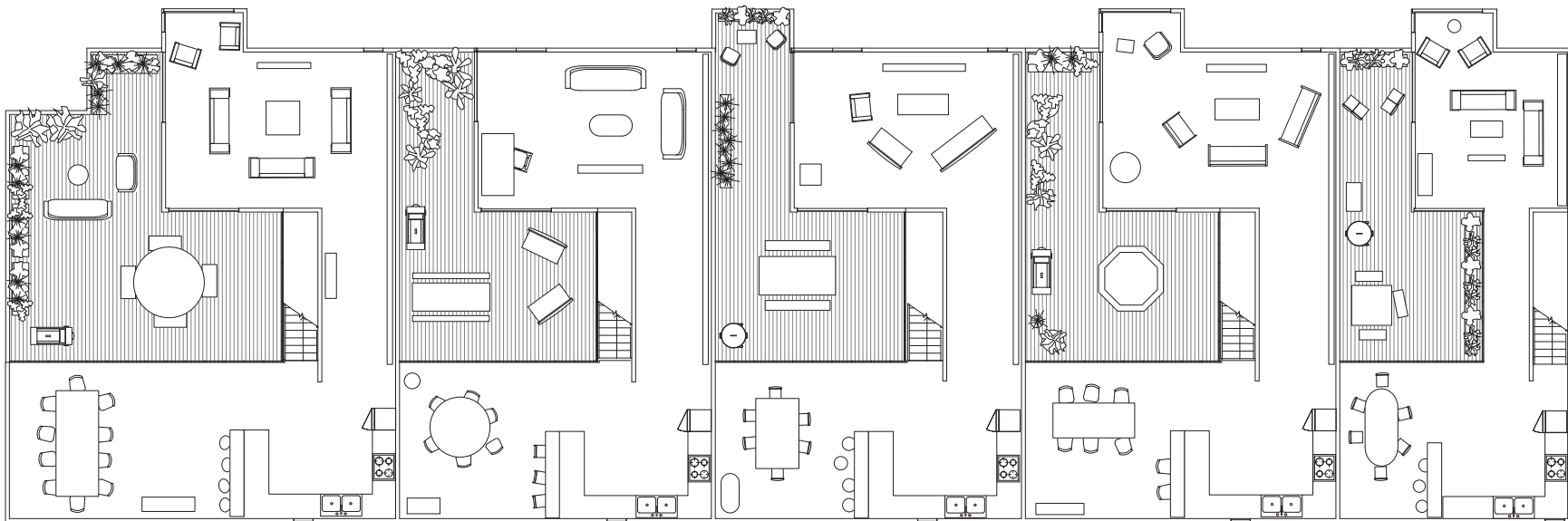

Figure 3.74 - Second floor plan
Source: Authors own image

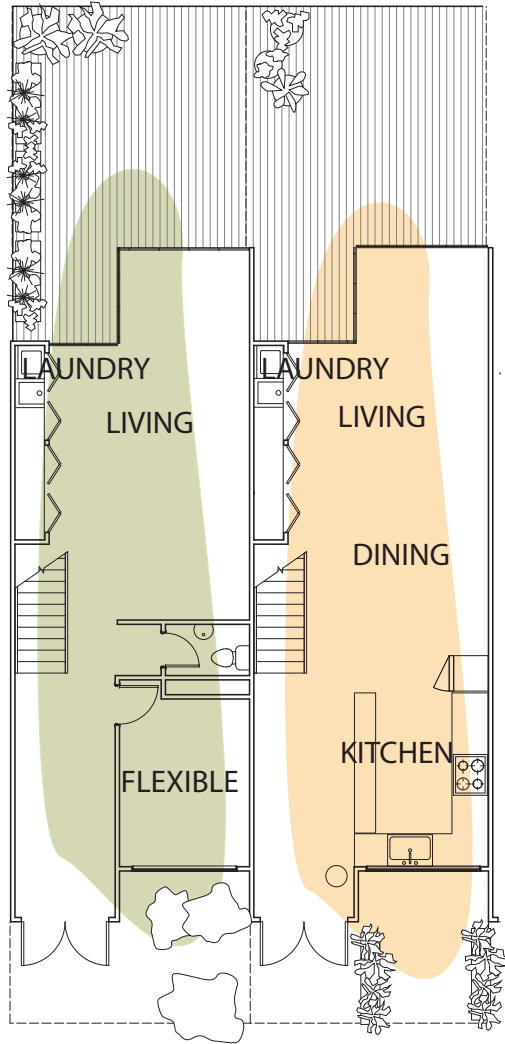

Figure 3.76 - Typical ground floor plan showing two units, large (left), small (right)
Source: Authors own image

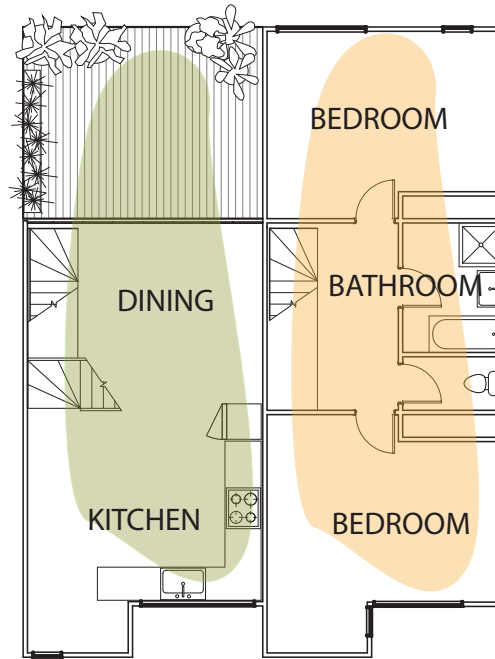

Figure 3.77 - Typical first floor plan showing two units, large (left), small (right)
Source: Authors own image

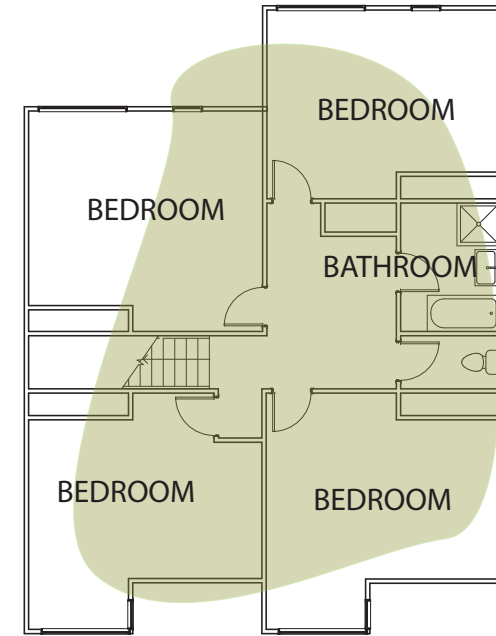

Figure 3.78 - Typical second floor plan showing one unit, large
Source: Authors own image



Figure 3.79 - Typical dining room and deck in large unit
Source: Authors own image

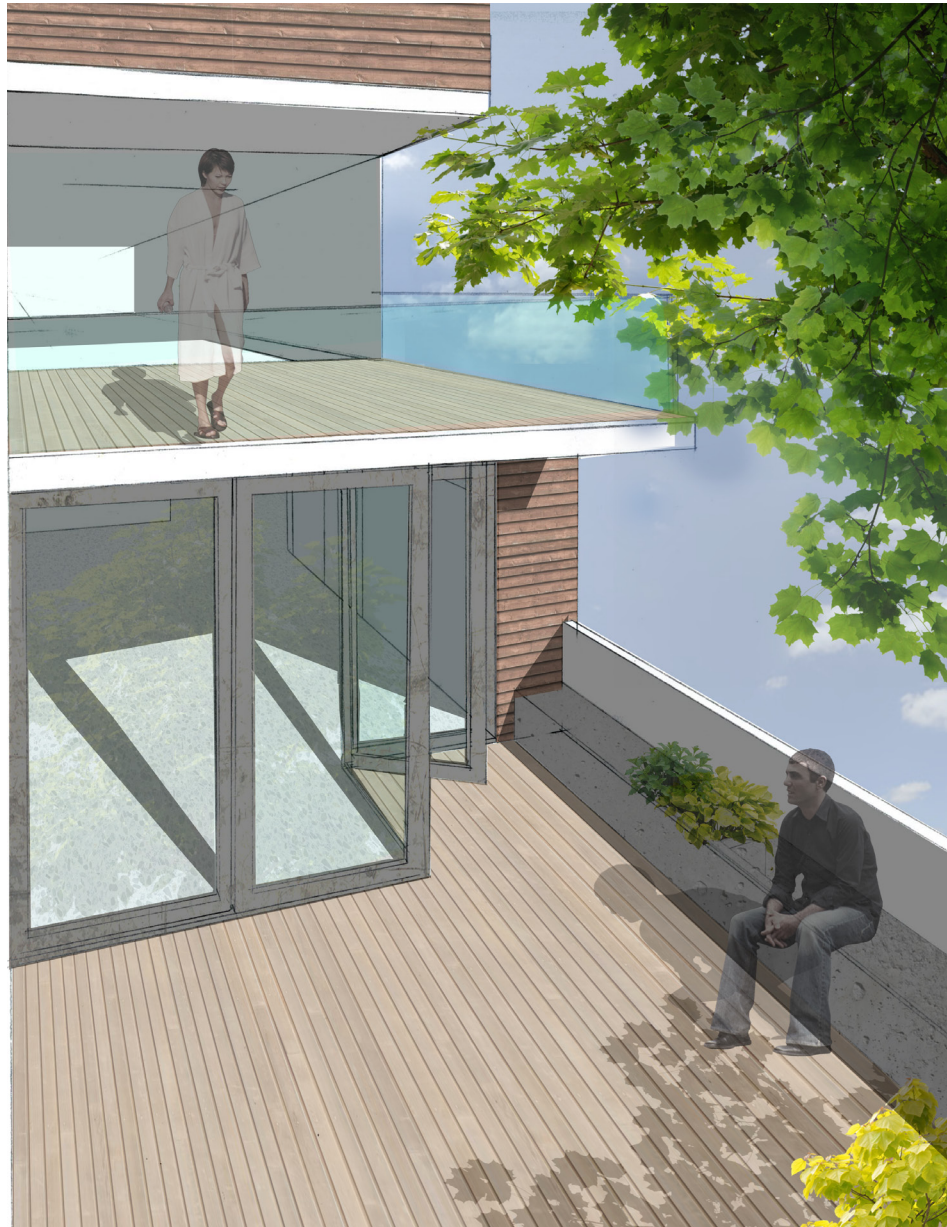

Figure 3.80 - Typical ground floor and first floor deck in large unit

Source: Authors own image

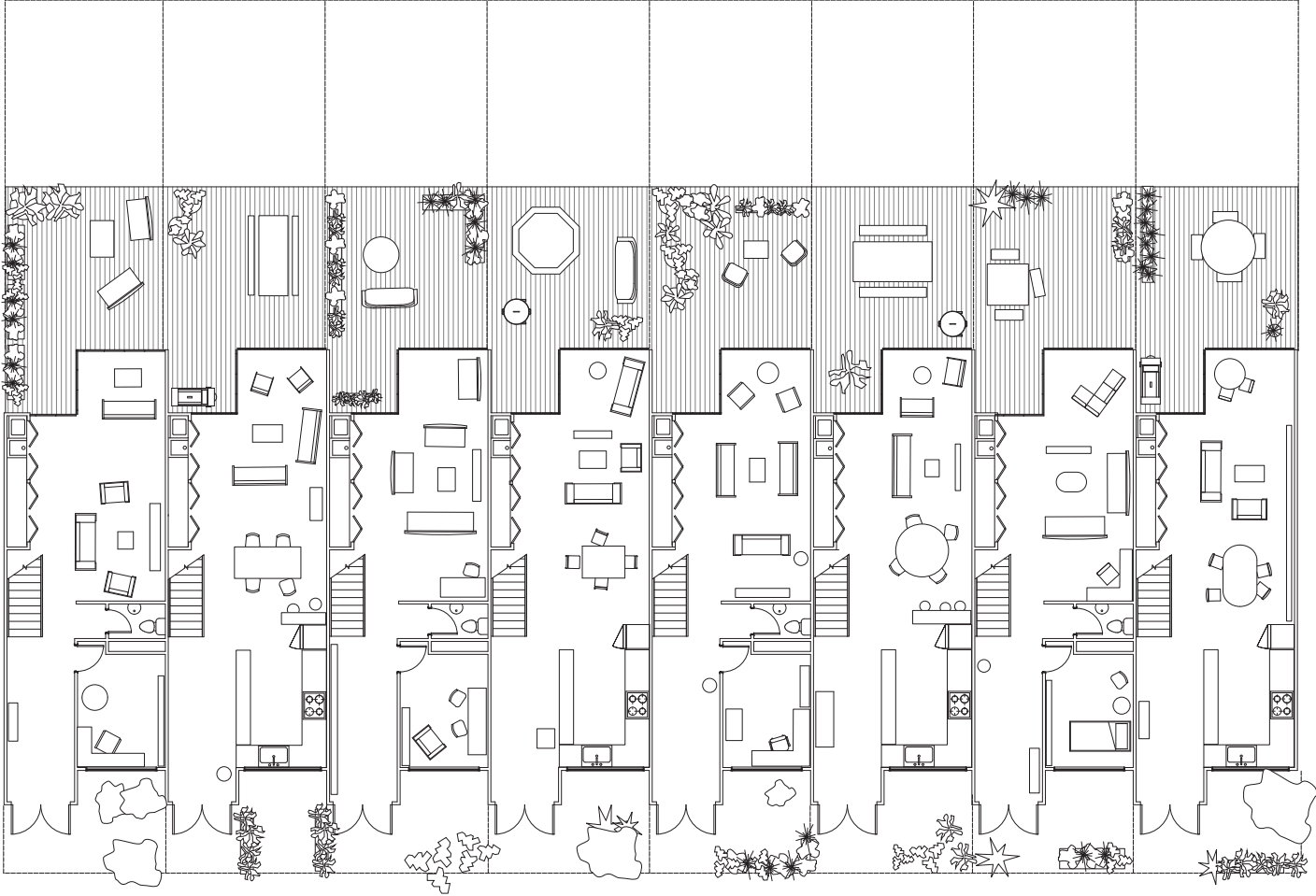

Figure 3.81 - Ground floor plan
Source: Authors own image

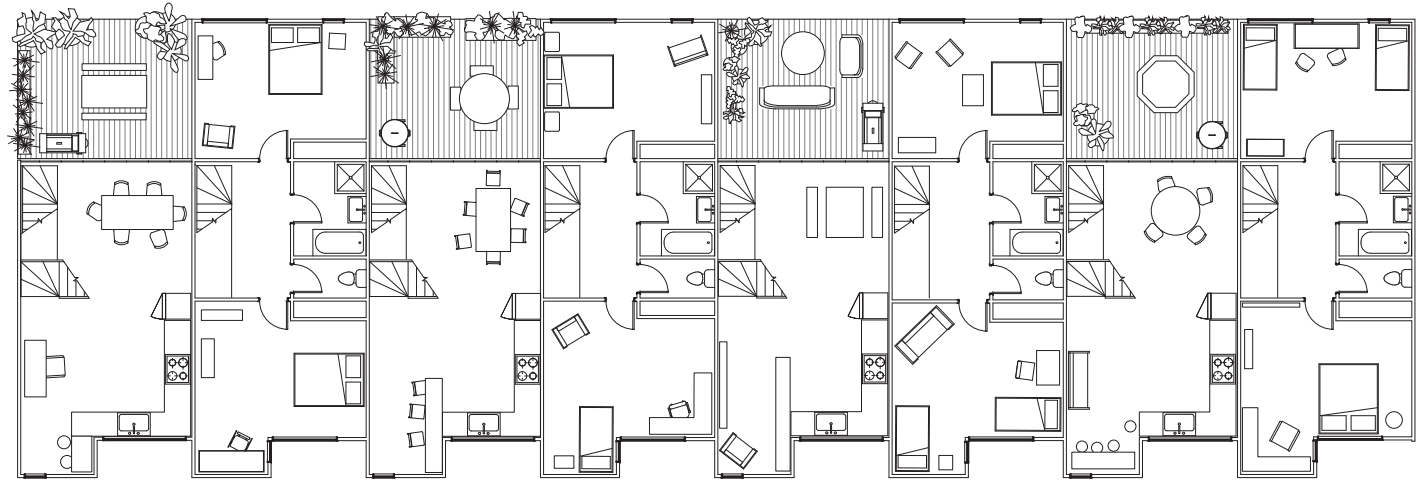

Figure 3.82 - First floor plan
Source: Authors own image

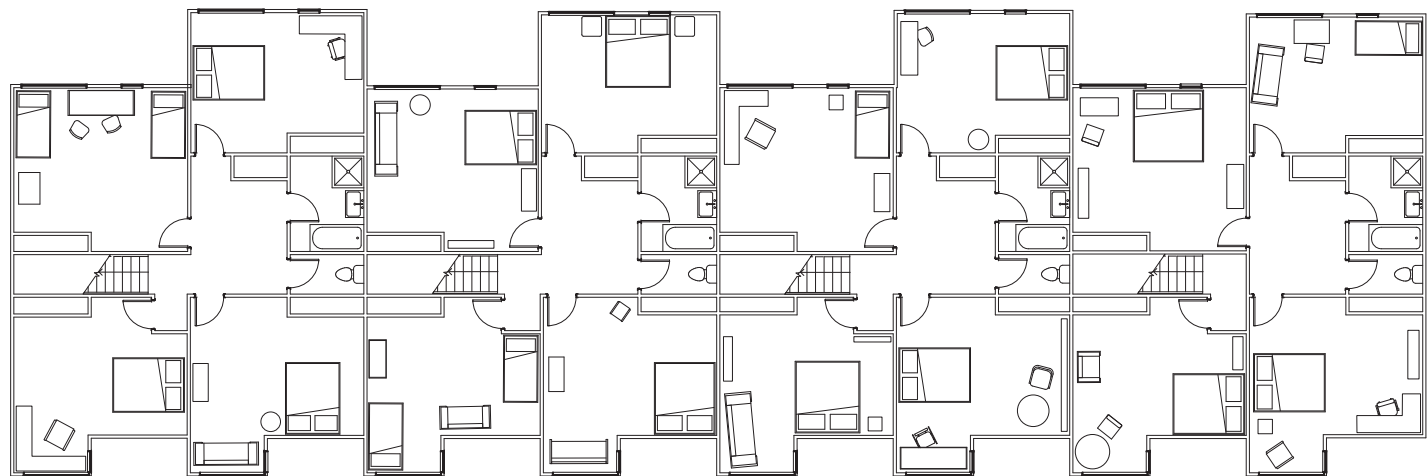

Figure 3.83 - Second floor plan
Source: Authors own image

Planning for future adaptation

A number of strategies were integrated into the plans in order to ensure potential for future adaptation.

Circulation position

Vertical circulation is located at the side of each plan so that it doesn't take up a large amount of room. Future internal changes to rooms will still work with the efficiently located stairs. This arrangement has been proven in the adaptability of traditional townhouses.

Horizontal circulation is centralised with rooms accessed from a central point, or is taken out all together, with circulation through open-plan spaces rather than around rooms. This also increases the habitable floor area.

Large rooms

Rooms are kept large so that they can be used for a variety of activities. Bedrooms can be used as studies, libraries, offices or storage. They can be divided into smaller rooms in the future, the square proportions becoming rectangular rooms

Services

Laundries, bathrooms and kitchens are stacked vertically to reduce the amount of space needed for plumbing. Bathrooms are located in the middle along the side wall, allowing future room changes to take place around them.

Load-bearing walls

There are no internal load-bearing walls within each dwelling so that internal spaces may be reconfigured in the future. A structural steel framing system is used in the walls between each dwelling.

The units all have the potential to be further subdivided internally, increasing the dwelling density. They also have the potential to be combined into larger units if necessary.

Section - providing diverse dwelling types and sizes

Manipulating internal configuration to accommodate diverse dwellings

To provide choice for different demographic groups and family sizes a range of unit sizes and types were designed. The challenge was to fit irregularly sized and shaped units into a continuous block of housing.

The north-facing site has one, two, three, and four bedroom homes, all with a flexible room as well. The south-facing site has two and four bedroom homes. Appendix B (pg. 182) contains some of the process sketches showing the design development of the internal configuration.

North:

Different strategies for achieving a mix of dwelling sizes within one block of attached housing were trialled. The design was constrained by the desire to have ground level street access for each unit. This led to experimenting with the internal arrangements of the units in relation to each other. The ground floor units on the north side are all the same to preserve street and back garden access for each unit, but on the first floor they start to weave and overlap. By overlapping the units in section, variety within the amount of bedrooms and living space was able to be achieved.

On the second floor, the larger units are overlapped on top of the smaller units, making large living spaces possible. It also allows space for a large roof terrace that is integrated with the living and dining spaces.

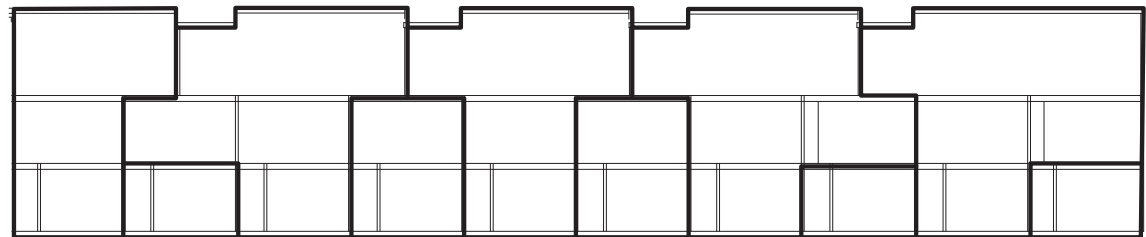
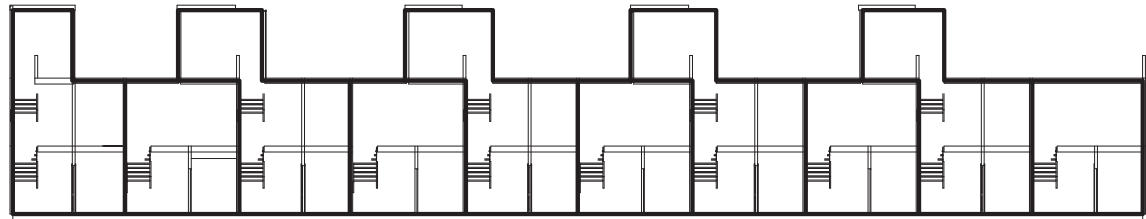
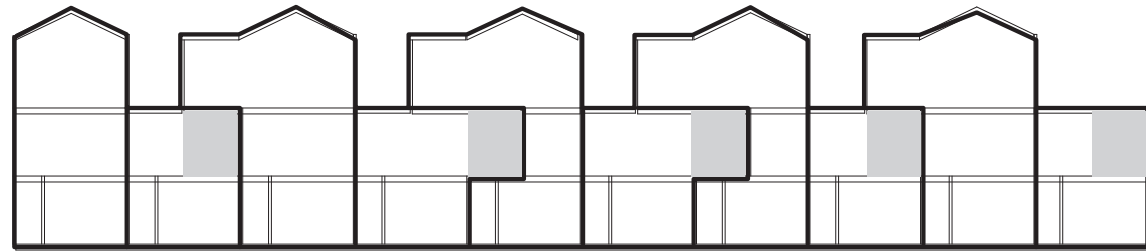

Figure 3.84 - Longitudinal sections
Source: Authors own image

Figure 3.85 - Cross section through one house (ground floor: hallway, first floor: bedrooms, stairs, second floor: living room, lightwell, kitchen)
Source: Authors own image

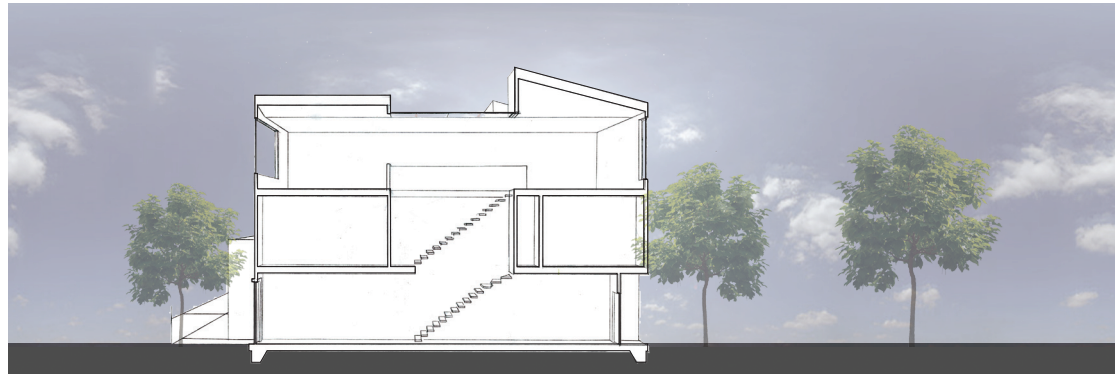
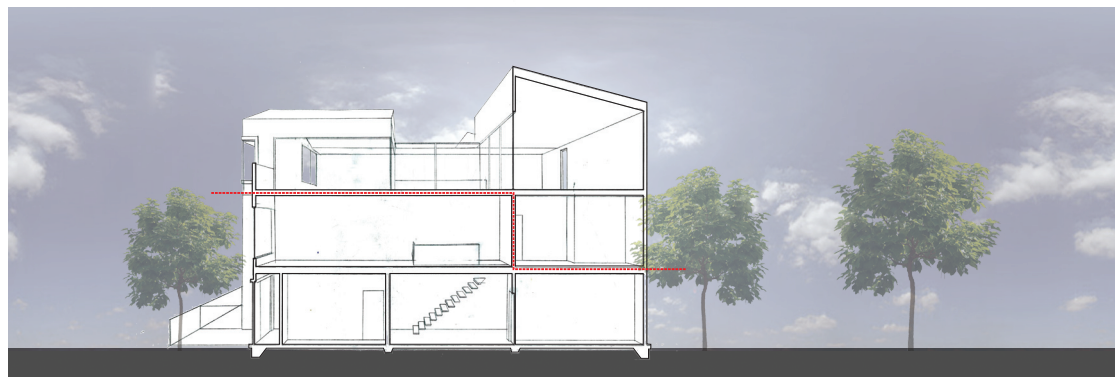

Figure 3.86 - Cross section through one house (ground floor: flexible room, laundry, bedroom, first floor: bedrooms and bathroom, second floor: living room, courtyard, dining room)
Source: Authors own image



Figure 3.87 - Cross section through two houses (small house: first floor: flexible room, hallway, bedroom, first floor: living and kitchen, large house: first floor: bedroom, second floor: terrace, dining room)
Source: Authors own image



South:

The south-facing design has small and large units, but these are more homogenous than those on the north, only two and four bedrooms units are supplied. It is envisioned that this will still provide adequate choices for a range of demographic groups. Here the overlapping only starts on the second floor, where the larger unit completely overlaps the smaller to provide room for more bedrooms. The arrangement of these units doesn't need to be as complex as the north-facing design as private outdoor space doesn't have to be integrated within the building envelope to such a high degree.

Detail design considerations

The overlapping dwellings raise the problem of acoustic and fire separation. Typical townhouse developments only need to be separated on either side of each unit. With these designs the separation needs to extend behind and above the units.

This will increase the cost of construction; however, the amenity gained from having a wider demographic appeal arguably justifies this cost.

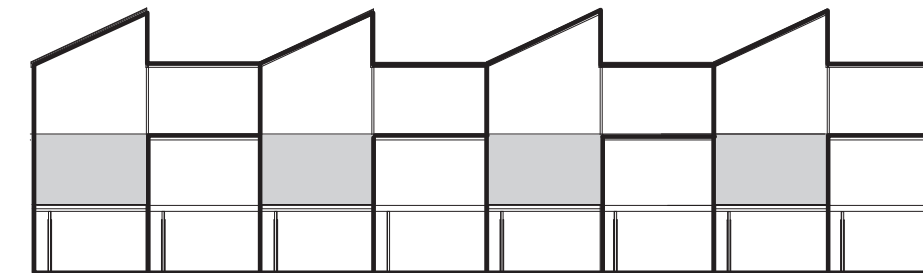
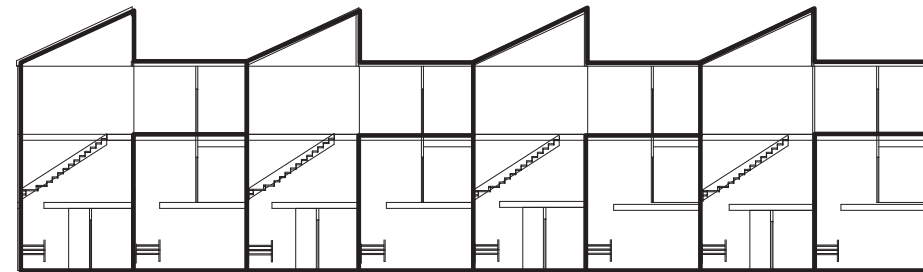
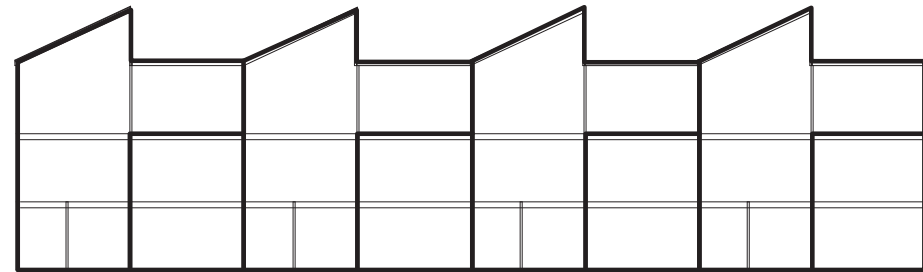

Figure 3.88 - Longitudinal sections
Source: Authors own image

**Figure 3.89 - Cross section through one house
(ground floor: deck, living area, first floor: terrace,
dining room, kitchen, second floor: bedrooms)**

Source: Authors own image



**Figure 3.90 - Cross section through two houses
(ground floor: deck, living, dining, kitchen, first
floor: bedrooms, second floor: bedrooms)**

Source: Authors own image



Elevation - integrating into existing streetscape

Once the planning was resolved, the next step was to work out design strategies that would help to integrate the design into the context and preserve the local character. The Victorian townhouse is analysed and reinterpreted to generate design ideas. This section will discuss how the two buildings are designed to integrate into the context; they will be discussed together because there are many elements shared by both. Most of the discussion regards the street-facing elevation, as this is the main part of the building seen and experienced by the public.

Victorian townhouse – analysis of architectural elements

The typology of the two-storey Victorian townhouse was chosen for further study because the medium-density development will be replacing several one-storey bungalows. The repetition of the townhouse has provided much of the street's unique sense of place, so in order to integrate a new development into the street the design will reinterpret elements from the Victorian form. Formal analysis is of the set of five townhouses built to the same plan in 1906 (figure 3.91). They are analysed as individual houses, and also for the effect created when the units are repeated.

The architectural elements that make up the Victorian townhouse are analysed in order to find ways in which to integrate the new design into the context. Traditional architectural elements such as massing, proportioning systems, fenestration, rooflines, entrance, materials, and articulation are all examined both separately, and in terms of how they contribute to the whole.



Figure 3.91 - Five Victorian townhouses, built to the same plan in 1906

Source: Authors own image

Proportions

The main proportioning system is 2:1. This is seen in the massing, i.e. the double storey and the projected right-hand half of the façade. It is also seen in the fenestration; the windows are squares divided in half vertically by the window frame, and divided again, horizontally, by the window sash.

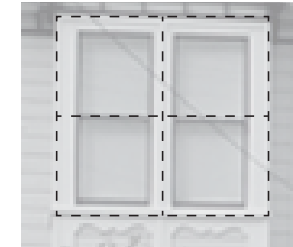
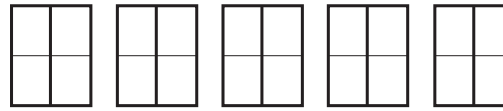

Figure 3.92 - Proportions diagram

Source: Authors own image

Massing

Massing is relatively simple; the right hand side of the front façade is projected out with bay windows, which enhances a vertical reading of the mass. The repeated houses form a regular pattern along the street of recesses and projections.



Figure 3.93 - Massing diagram

Source: Authors own image

Fenestration

Each façade has a door and large bay window on the ground floor. On the first floor a single window sits above the door, and a large bay window sits directly on top of the first one. The vertical window division is articulated much more than the sash, meaning the windows are read as vertical openings.



Figure 3.94 - Fenestration diagram

Source: Authors own image

Entrance

The entrance is defined by a recessed space on the left of the front façade. This is protected by a verandah that is articulated in a variety of ways.

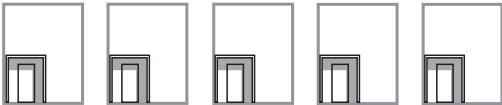

Figure 3.95 - Entrance diagram

Source: Authors own image

Roofline

A small pitched roof over the projecting right side brings more attention to this side of the façade. The pitch is approximately 25 degrees. Behind this the traditional hip roof recedes away from the viewer.

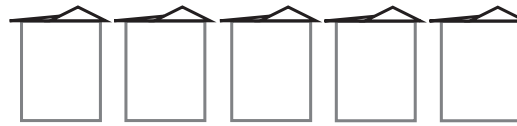

Figure 3.96 - Roofline diagram

Source: Authors own image

Materials

Because of the time in which they were built the townhouses are framed, clad, and detailed in timber. The cladding system is rusticated weatherboards with timber siding. Window frames were factory-made and ordered from a catalogue, these are also timber. All detailing is timber mouldings that would also have been factory-produced.

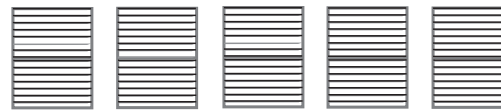

Figure 3.97- Materials diagram

Source: Authors own image

Articulation

In comparison with many other houses built in the Victorian tradition in Wellington, Roy Street's townhouses are relatively spare and unadorned. Only their thick timber frames articulate the windows, while simple timber moulded cornices and a finial ornament the roofline.



Figure 3.98 - Articulation diagram

Source: Authors own image

Colour

The houses have all been painted different colours by their owners, but overall the palette is pale and neutral. Darker colours are used to pick out the window frames and timber detailing.



Figure 3.99 - Colour diagram

Source: Authors own image

All of these elements come together to form a composition that reads on many levels; from individual details, to a house, to a row of houses defining the street edge.

It contributes to a lively, visually interesting streetscape. The closely-knit houses form a continuous elevation, and the repeated elements of massing, fenestration, and materials form a pattern that is kept from becoming too repetitive by individual touches to each house.



Figure 3.100 - Overall diagram

Source: Authors own image

Integrating the design into the built character of Roy Street

By reinterpreting the architectural elements of the Victorian townhouse, the new developments will integrate into the built form and character of Roy Street.

The design process involved testing different configurations of elements, and testing them against the existing street elevation. These were then evaluated for the level of disruption or continuity created with the existing patterns. The elevations developed incrementally as design ideas were included or discarded. Appendix C (pg. 184) shows some of the development of the various facade elements.

Proportions

The width of each dwelling is similar to the width of the Victorian townhouse so the scale of the new development sits comfortably in the street. The Victorian townhouse used a proportioning system of approximately 2:1, this is carried through into the designs through massing and fenestration.

134

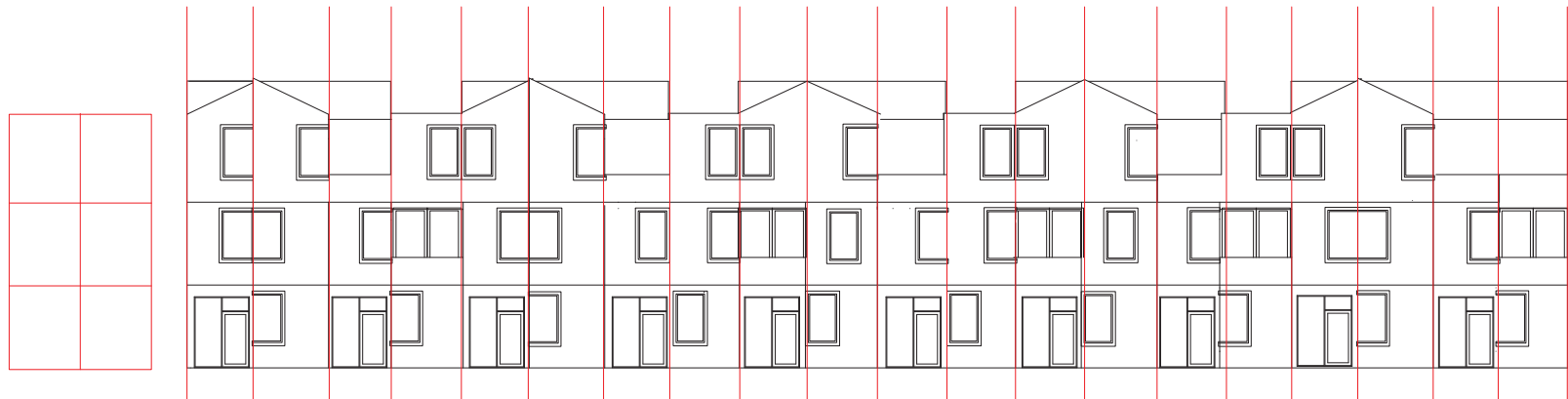

Figure 3.101 - Proportions diagram - north-facing design

Source: Authors own image

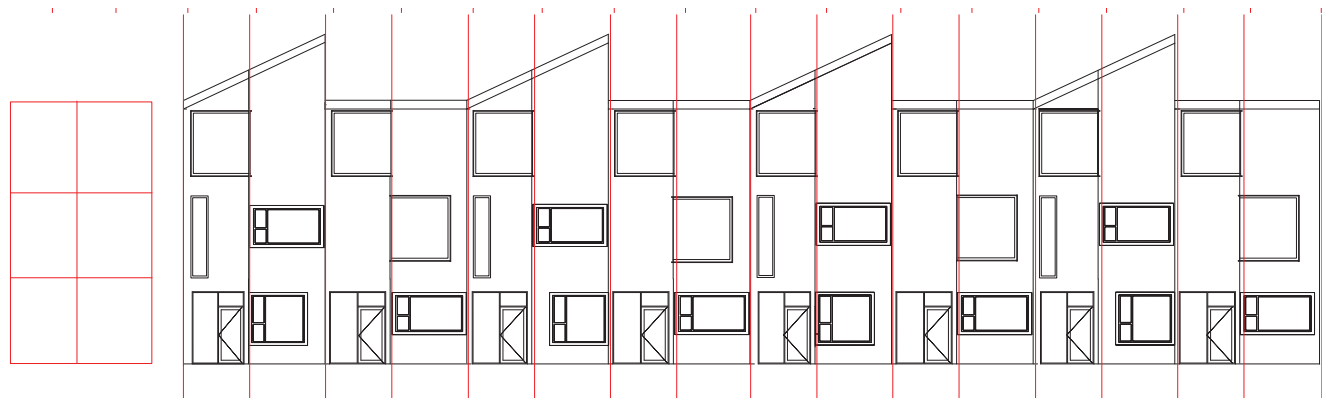

Figure 3.102 - Proportions diagram - south-facing design

Source: Authors own image

Massing

As seen in the literature review, massing can be used to enhance reading of the development as individual dwellings rather than an impersonal block. The study of the massing of the Victorian townhouses is applied to both designs. The vertical reading is achieved by stepping the facade in and out. The projections are the same proportion as the Victorian houses, so the design continues the pattern of extrusions and recesses along the street. The north-facing design has a complex massing due to the complex internal configuration. The massing pattern is based on the location of the first-floor balconies. The south-facing design has a far simpler, repetitive massing pattern because it is more simple internally.

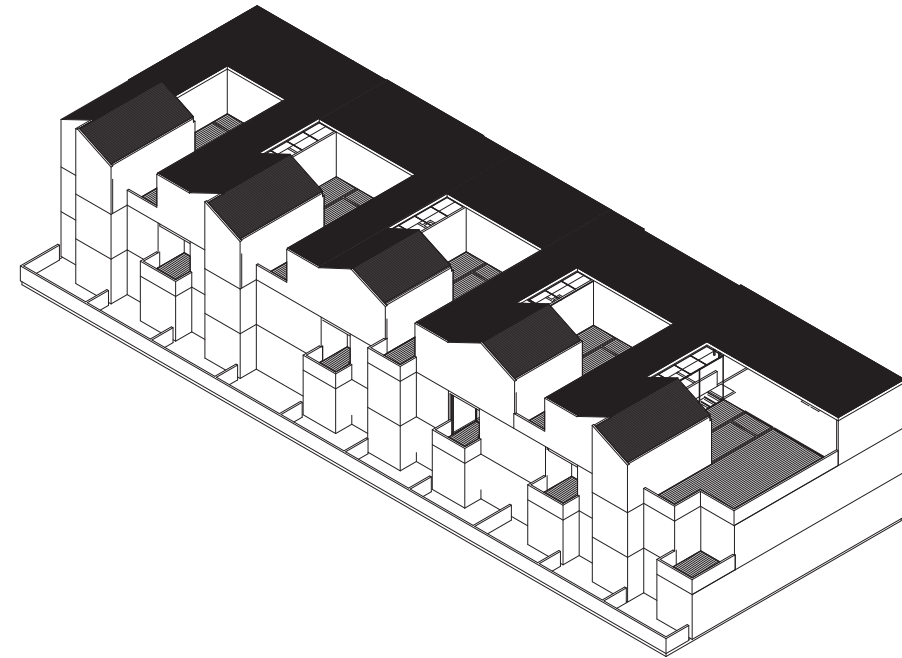

Figure 3.104 - Three-dimensional massing diagram - north-facing design

Source: Authors own image



Figure 3.103 - Massing diagram - north-facing design

Source: Authors own image

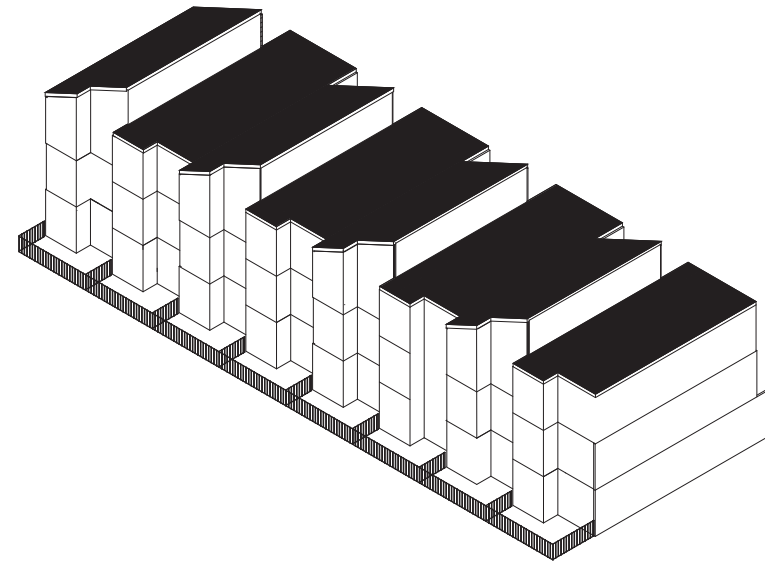

Figure 3.106 - Three-dimensional massing diagram - south-facing design
Source: Authors own image



Figure 3.105 - Massing diagram - south-facing design
Source: Authors own image

Fenestration

The internal spaces behind the facade on the north facing building are varied and lack a regular arrangement which inevitably led to an irregular facade pattern. The appearance of irregularity was reduced by only having one window type – a vertical rectangular window which is doubled for living spaces, and kept single for bedrooms and flexible rooms. The window proportions were derived from the 2:1 Victorian proportions – the single rectangle refers the single townhouse window while the doubled rectangle refers the bay window proportions. Openings are also placed in the sides of the projected facades in order to draw varied light into the rooms, and as a further reference to the bay window. The overall pattern of fenestration is designed to reference the scale, proportions, and positioning of the Victorian fenestration, and to read as an extension of the pattern along the street.

138

Figure 3.108 - Fenestration - north-facing design

Source: Authors own image

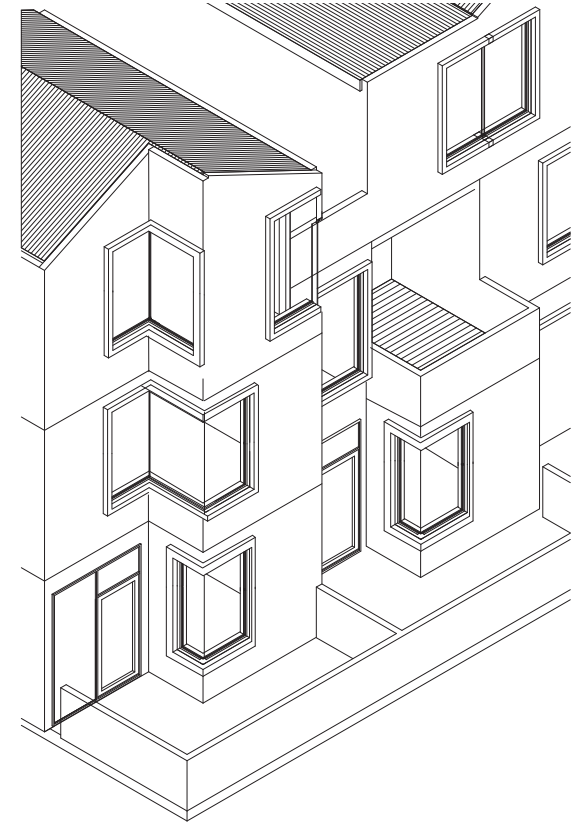

Figure 3.107 - Fenestration diagram - north-facing design

Source: Authors own image

The south facing building has a much more regular internal arrangement which is repeated throughout the building. This has led to a very regular facade. Because it faces south, openings don't need to be so large; therefore the fenestrations appear more dispersed across the facade. In order to increase visual interest there are three types of fenestration; an almost square window for bedrooms, a large horizontal window for kitchens, and a tall narrow window for circulation. The bedroom windows fold along the sides of the projections in order to vary the natural light that the south-facing rooms receive.

Figure 3.110 - Fenestration - south-facing design

Source: Authors own image

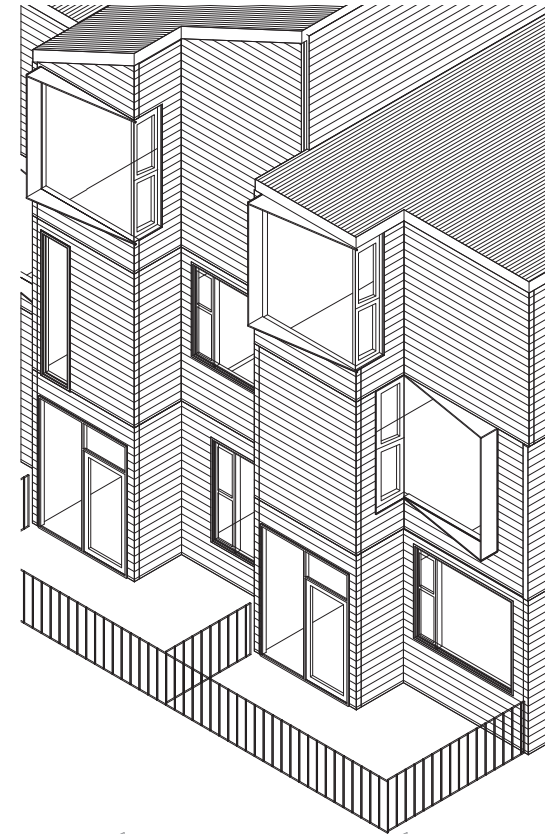

Figure 3.109 - Fenestration diagram - south-facing design

Source: Authors own image

Roofline

The 25 degree angle of the Victorian pitched roof is retained but reinterpreted. The north-facing design plays on the typical pitched roof, while the south-facing design retains the same pitch but becomes mono-pitch. The flat side of the mono-pitch roof allows a skylight to increase the level of natural light in the second-floor hallway. The varied roof forms help to increase the perception of separate dwellings rather than a homogenous block.

140



Figure 3.111 - Roofline diagram - north-facing design

Source: Authors own image



Figure 3.112 - Roofline diagram - south-facing design

Source: Authors own image

Materials

The Victorian townhouses are clad in rusticated timber weatherboards. Timber weatherboards are the most common cladding material in Wellington, so this tradition is carried on within the design, but interpreted in a contemporary manner. Rainscreen cladding is an effective way to mitigate the effects of wind-driven rain, which has been a problem with recent residential construction materials and methods.

The north-facing facade uses a timber rainscreen, with horizontal boards echoing the weatherboard pattern. It is made contemporary by using flat boards, relying on the line between each board to create the pattern, rather than a shadow. The boards meet flush at the corners, without siding, which makes the appearance more contemporary, and is made possible by the rainscreen detail.

On the simpler south-facing facade the cladding has a stronger presence in order to increase visual interest. Here a more traditional bevel-back weatherboard is used in the rainscreen, but is made contemporary by keeping a natural wood finish and using steel cap sidings.

142

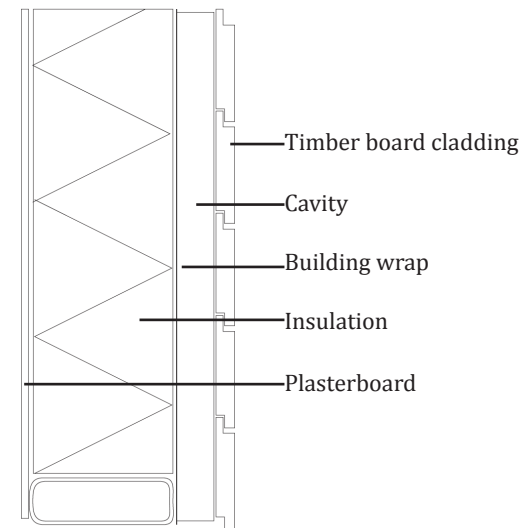
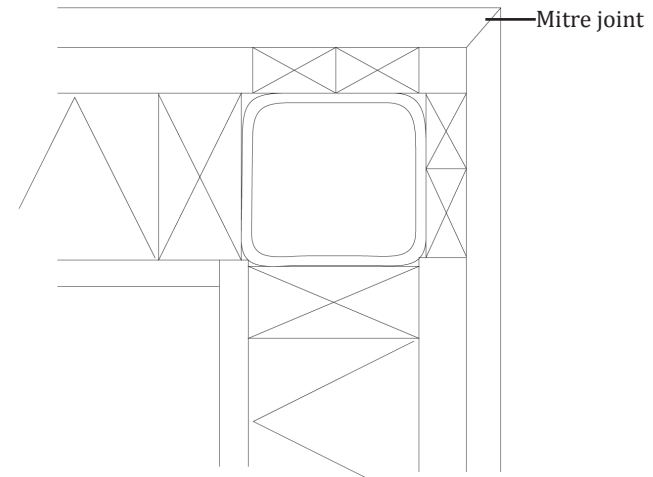

Figure 3.113 - Exterior cladding details - north-facing design

Source: Authors own image

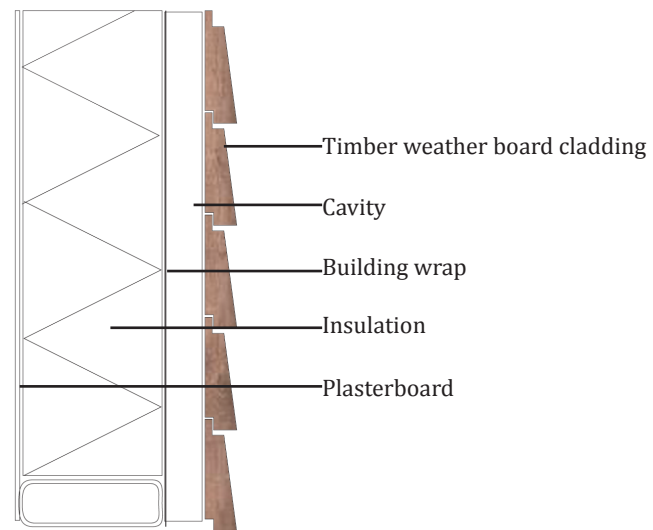
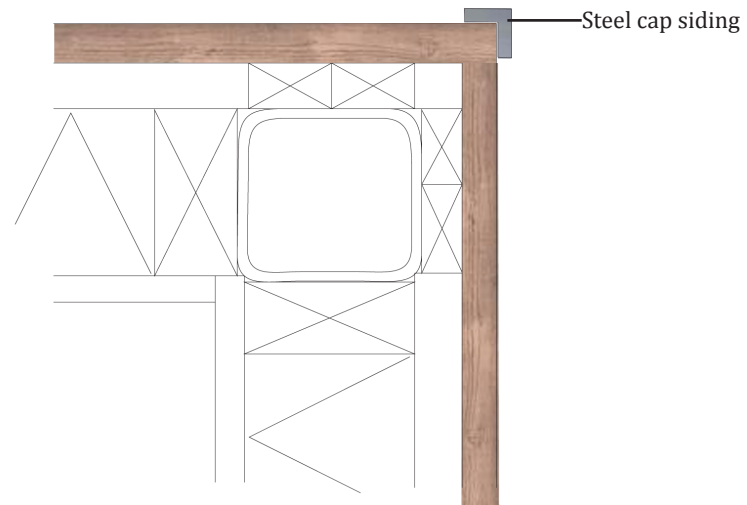

Figure 3.114 - Exterior cladding details - south-facing design
Source: Authors own image

Articulation

The window frames on the north-facing facade are highly articulated with a thick frame like the Victorian ones. The frames project from the facade, but are simplified and are double-glazed with aluminium frames rather than timber. Articulation is limited to windows to reduce visual clutter.

Because the fenestration pattern on the south-facing facade is extremely regular, the pattern is interrupted and visual interest is created by varying the articulation of the windows. A copper angled frame around the bedroom windows departs from the Victorian tradition but is in keeping with the overall scale. The frames of the other windows are aluminium, contrasting with the natural timber cladding. The roof edge is also articulated with a copper border.

144

Figure 3.116 - Typical window - north-facing design

Source: Authors own image

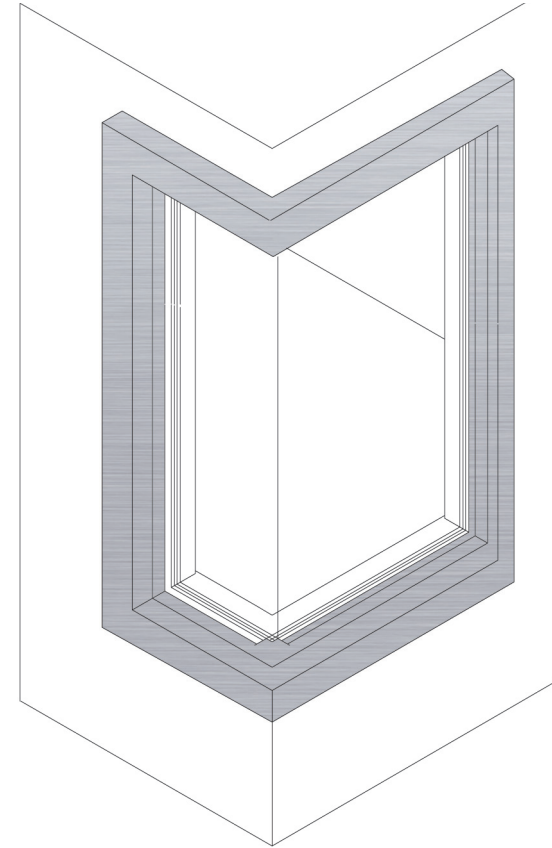
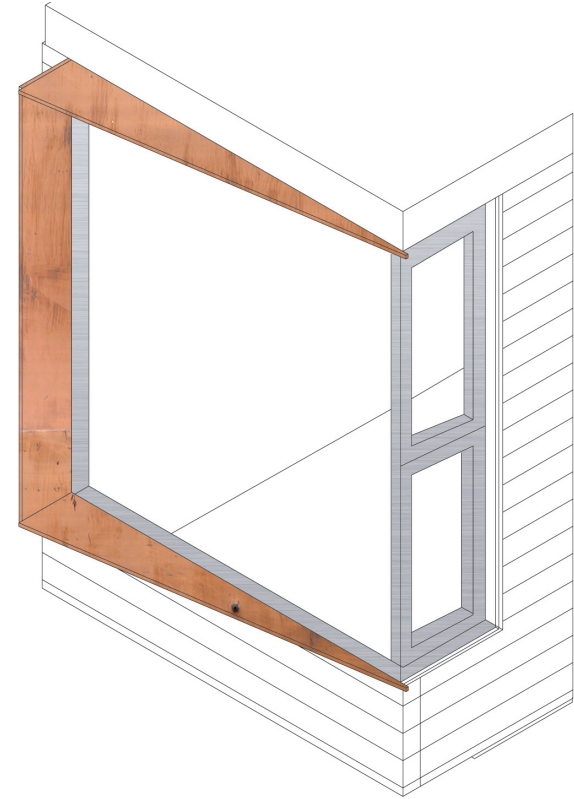

Figure 3.115 - Articulation diagram - north-facing design

Source: Authors own image

Figure 3.118 - Typical window - south-facing design

Source: Authors own image



145

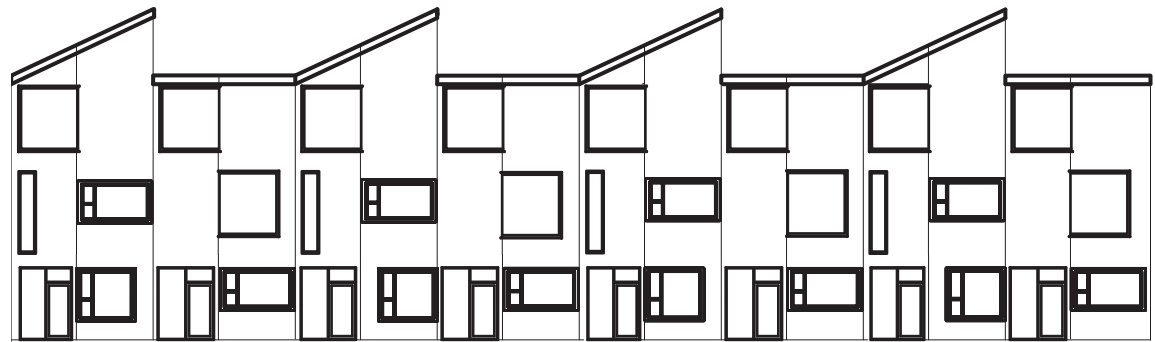

Figure 3.117 - Articulation diagram - south-facing design

Source: Authors own image

Colour

The colour palette of the north-facing design is kept neutral; white painted timber boards compliment the light neutral colours of the neighbouring houses. Window frames are aluminium, contrasting with the pale cladding in the same way as the Victorian townhouses do.

The south-facing houses have natural timber cladding, relating to the natural environment surrounding the site. This natural cladding is contrasted with copper and aluminium window frames.

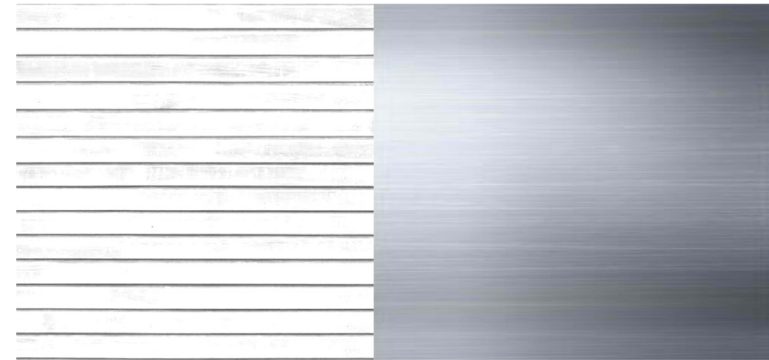

Figure 3.119 - Colour scheme - north-facing design

Source: Authors own image



Figure 3.120 - Colour scheme - south-facing design

Source: Authors own image

Entrance

The entrance to each unit is located at the left-hand side, like the Victorian townhouses, when looking from the street. This gives each dwelling an easily identifiable entrance.



Figure 3.121 - Entrance diagram - north-facing design

Source: Authors own image



Figure 3.122 - Entrance diagram - south-facing design

Source: Authors own image

Ground treatment and planting

The front garden provided is the same size as the Victorian neighbours. This will enable residents to grow plants of their choice, and providing a filter between the street and the house. Existing trees will be retained. The fence line is kept consistent with the rest of the street, and is constructed from timber.

The balconies on the north-facing facade allow greenery to be incorporated, further enhancing the overgrown natural character of Roy Street.

Figure 3.124 - Front garden plan - south-facing design

Source: Authors own image

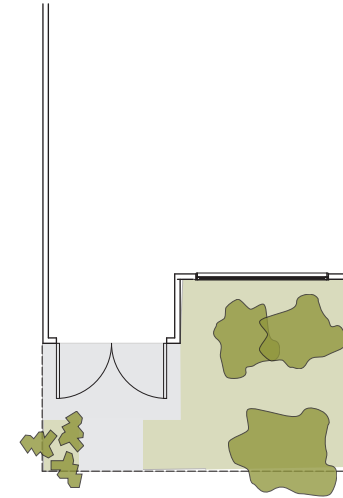

Figure 3.123 - Front garden plan - north-facing design

Source: Authors own image

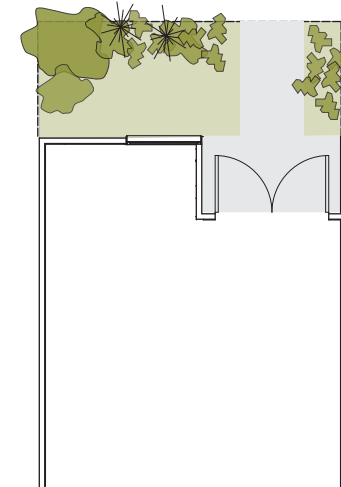



Figure 3.125 - Front garden - north-facing design
Source: Authors own image



Figure 3.126 - Front garden - south-facing design
Source: Authors own image

Integration into context

By reinterpreting the basic architectural elements of the Victorian townhouse in a contemporary manner, the design is able to integrate into the existing street context. Drawing from the local character will allow the design to be more accepted by residents as it doesn't detract from the unique sense of place, and it expresses the next step in the evolution of the built form.

150



Figure 3.127 - Street elevation in context - north-facing design

Source: Authors own image



Figure 3.128 - Street elevation in context - south-facing design

Source: Authors own image



Figure 3.129 - Street elevation - north-facing design

Source: Authors own image

Figure 3.131 - (next page) Street perspective - north-facing design

Source: Authors own image

Figure 3.132 - (following page) Street perspective - south-facing design

Source: Authors own image



Figure 3.130 - Street elevation - south-facing design

Source: Authors own image





Design discussion

The case-study design proposed a synthesised solution to a range of disparate problems. It met the initial aims of the brief that were established from the literature and precedents review, and the site studies. The design has potential applications beyond the specific time and location of the case-study site as it has the potential to be adapted, and the underlying principles can be applied to other sites.

Assessment and evaluation of design solution

Designing for the street grid

By basing the design on a common condition found across Wellington, it has the potential to be applied on a wide range of sites. Limiting intensification to the suburbs with gridded street networks take the pressure off greenfield land and steep, difficult to build on sites. It also makes greater use of existing infrastructure and local amenities.

The specific but replicable conditions of the grid street network have provided the initial starting point of the design. By planning around the grid conditions the design is able to respond to its site.

The design proposes a process of incremental change to the existing urban form. By replacing obsolete houses with medium-density blocks that still fit with the historical grain the suburbs will slowly increase in density while maintaining local character (figure 4.1).

Plan – efficient layout, responding to site conditions

The planning is space efficient, and has inherent capacity to adapt to future change. By developing two sets of plans based primarily around sun orientation and connection to private outdoor space liveability is enhanced. The plans are able to be located on any of the gridded sites and will be responsive to the site conditions. The positioning of circulation and services will allow future changes to take place easily by the addition of partition walls.

Section – accommodating diverse demographic groups

Manipulating the section of each design allowed varying-sized dwellings to exist within a continuous building envelope. This increases the range of choice available for the emerging demographic groups that are no longer catered for by detached single-family housing. The north-facing design provides one, two, three, and four bedroom dwellings, while the south-facing design has two and four bedroom units. The living spaces are varied in terms of size,

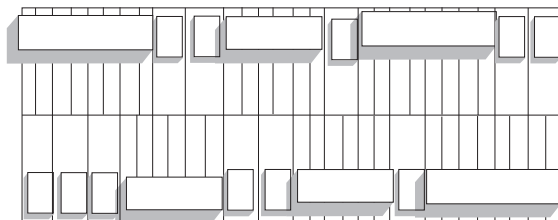
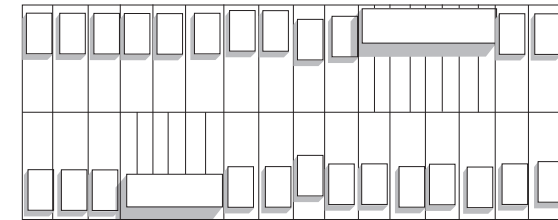
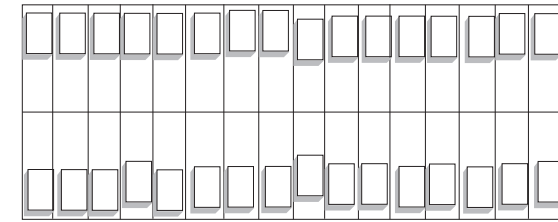

Figure 4.1 - Block redevelopment - incremental increase in density over time

Source: Authors own image

type, and connection to outdoor space. This type of sectional manipulation can be done in multiple ways, leading to even more varied dwellings.

Elevation – integrating into local context

The architectural elements of the Victorian townhouse were reinterpreted in order to integrate the new design into the existing scale and pattern of the street. The design sits in its context as an identifiably contemporary building, while retaining much of the Victorian character.

Other considerations

The design has potential to adapt in programme and location.

Future increase in dwelling density

Flexibility or capacity for change has been designed into the plans so that the houses may be able to be adapted for different uses, or the number of dwellings increased in the future.

160

The bedrooms are large enough to be divided into smaller rooms or used as living rooms. They can also accommodate other activities such as study, home office, or practice room. The open plan design of the living, dining and kitchen areas mean that the spaces can be used in different ways by altering furniture layout. These can also be easily subdivided into smaller rooms with partition walls.

The location of stairs and plumbing fixtures means that it would be relatively easy to subdivide each level internally. For example the current number of 10 and eight dwellings in the north and south designs respectively could increase to 30 and 24 one bedroom units.

On the north-facing site the roof terrace could be covered over to provide more living space. The first floor terraces in the south-facing design could also be covered to provide more internal space.

Application to other sites

The designs can be applied to varying-sized sites by altering the number of units built. Smaller sites could accommodate two to four dwellings. The recommended maximum number of dwellings per block is 10 so as not to overwhelm the street. The design case-study

used reasonably large sites, but the number of units could easily be varied depending on the width and number of available sites. The minimum required footprint would be 10 metres, accommodating two different-sized units.

The north-facing design would also be suited to west-facing sites as the elevated living spaces would receive afternoon and evening sun. The south-facing design would be effective on east-facing sites as the living room, back garden, and terrace would also receive afternoon sun, while the kitchen would have morning sun.

The principles used to analyse and reinterpret the Victorian townhouse context can be applied to other housing typologies and styles in other suburbs.

Principles

A series of principles have been extrapolated from the case-study design that can be applied to the gridded suburbs initially studied, and other similar sites.

Planning arrangement (figure 4.2)

The planning is based around basic considerations that will enhance liveability. Sun orientation, connection to private outdoor space, and efficient, adaptable organisation were the main planning drivers.

Providing varied dwelling sizes and types (figure 4.3)

Complex internal configuration can vary the types and sizes of dwellings, and the number of bedrooms. This can be done in different ways by altering the section depending on the desired dwelling types.

162

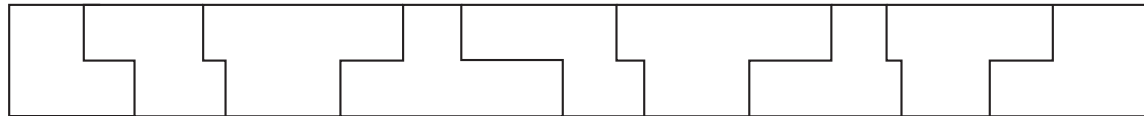

Figure 4.3 - Changing section providing different dwelling sizes

Source: Authors own image

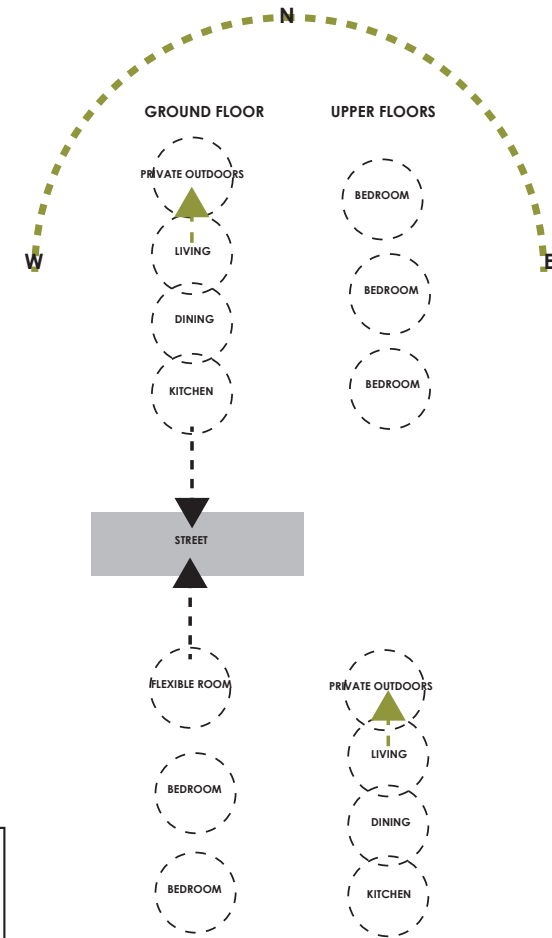

Figure 4.2 - Planning for sun orientation - South and east-facing sites (top), north and west-facing sites (bottom)

Source: Authors own image

Strategies for integrating into local context (figure 4.4)

The strategy of analysing the context can be applied to any suburb, and the results interpreted according to the individual designer. However there is a strong Victorian built heritage in Wellington, so several of the design techniques would be suitable on other sites. The built elements that should be assessed and reinterpreted are: proportions, massing, fenestration, rooflines, entrance, materials, articulation, colour, and street-front outdoor space.

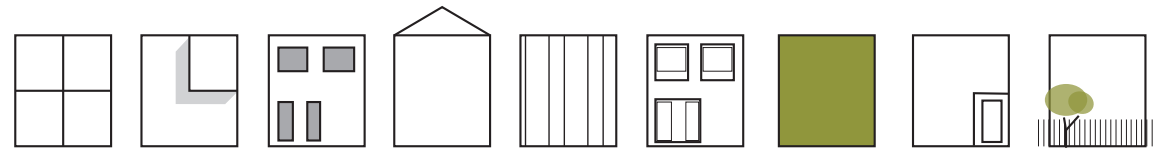

Figure 4.4 - Architectural elements for reinterpretation and integration into existing context (proportions, massing, fenestration, roofline, materials, articulation, colour, entrance, ground treatment and planting)

Source: Authors own image

Aspects outside scope of thesis

Streets may need to be altered to enhance connectivity in some areas. Some of the grid street networks studied had overly large blocks with under-utilised space in the middle. Subdividing these blocks with further streets could enhance connectivity and create more sites for intensification.

Structural and detail design considerations haven't been addressed in much depth as the focus of this investigation has been on a broader urban and planning scale.

Conclusion

Wellington's projected population growth and decreasing household sizes is pushing demand for more housing. The balance of demographic groups has dramatically changed in recent years, and is predicted to become increasingly diverse. Traditional families are declining, while childless couples and singles are increasing. Other groups increasing in numbers include multi-generational families, single-parent families, and combined families.

These demographic groups are not catered for in the existing housing stock. Most houses in Wellington are detached single-family houses, many of which are deteriorating. In order to provide dwellings for the increased population and demographic groups new and more varied housing will need to be built.

However, it is undesirable to undermine Wellington's compact urban form by expanding the built area and the bounds of the city.

New housing will need to be provided within the existing city fabric, in line with the contemporary urban theories of smart growth, compact city, and urban consolidation. Housing strategies of residential intensification and infill housing can be used to sustainably accommodate future growth. However, to be acceptable to the existing community, the construction of new medium-density housing within existing areas must be in scale with the local area, and maintain the sense of place and character.

The initial aim of this research was to develop a medium-density housing typology that can provide choice for varied demographic groups while integrating into its surrounding context and responding to site conditions.

Several built and unbuilt precedents were explored in order to understand architectural responses to different aspects of the problem. Internal layouts were examined for flexibility, adaptation and responsiveness to site conditions. Complex internal configurations with overlapping and interweaving volumes demonstrated ways of providing diverse dwelling types within a single block. Design strategies for reinterpreting a historic built context were analysed.

In order to decide where to locate the design, an urban form analysis of Wellington was carried out. This led to the realisation that Wellington has two dominant suburban typologies due to its extreme topography: the regular street grid on flat land, and the twisted, windy streets on the hills. The flat street grids were chosen as the best location for intensification to take

place because they are highly connected and easy to build on. Most importantly, they have replicable conditions, allowing a single typology to be developed that is suitable for a wide range of sites.

The main design driver was the underlying urban structure of regular-sized blocks subdivided into rectilinear lots with narrow street frontage. This pattern of development was found across all the gridded sites studied in Wellington, so was the basis for developing a design that could be applied to all these sites.

Orientation to street and sun also became significant influences as the design needed to overcome the limitations of the site. In order to do this, two different strategies were developed, one for north orientation and one for south, to better respond to the street front and provide sun-filled living spaces.

The architectural solutions to the problem were explored using traditional architectural tools of plan, section, and elevation. The plan was used to create living spaces that are well integrated with private outdoor space and exposed to sun and natural light. The plan is also flexible, with potential to support future demographic changes. The section was manipulated to vary the sizes and types of dwellings within each building, providing choice and catering to a wide range of people. The elevation incorporated formal elements of the existing built typology to tie the design to its specific location.

From the specific design, general principles were extrapolated to tie the design back to its original urban consideration. The principles established for layout, diversity, and integration can all be applied to other sites. Therefore the design itself isn't intended to be replicated (creating the danger of a homogenous suburban context) but the underlying principles are. A unified strategy for intensifying existing residential areas is hereby achieved.

This issue has been important to resolve architecturally because it is a real and pressing concern. If well-considered strategies for housing the increasing population aren't provided Wellington's urban form is under threat. Poor quality and poorly located designs can undermine the compactness and local character of historic areas as witnessed in a number of Wellington suburbs.

Potential problems are detail and construction complexity. The complex relationship between tenancies will increase the amount of acoustic and fire detailing needed. This study may advance in future by looking more closely at the detail design considerations.

Studies from a more urban focus would also be beneficial – for example quantifying how the design could increase dwelling density if applied across a certain number of sites, and to establish the total amount of growth that could be absorbed through intensification. Urban form studies looking at the design across more suburbs would provide an insight into Wellington’s potential future morphological development. The principles extrapolated from the case-study could be applied to other sites to test their efficacy. Sites outside of Wellington could also be studied; similar suburban morphologies are seen in other New Zealand cities, while Australian cities also have similar forms and are facing many of the same social pressures.

Residential intensification has the potential to become one of the key tools in providing more housing choice for a diverse population while retaining compact urban form and local character. This thesis has proposed a new strategy for incrementally altering urban form and increasing density, building on Wellington’s existing underlying urban structure.

Bibliography

Works cited

Bartley, M. (2009). "Urban consolidation: making it happen." Planning News 35(8): 14-15.

Bentley, I., A. Alcock, et al. (1985). Responsive environments: a manual for designers. Oxford, Butterworth Architecture.

Brand, D. (2004). "Surveys and sketches: 19th-century approaches to colonial urban design." Journal of Urban Design 9(2).

Brown, B. B. and V. L. Cropper (2001). "New urban and standard suburban subdivisions: evaluating psychological and social goals." Journal of the American Planning Association 67(4).

Building Research Association of New Zealand (2007). Changing housing need. Study Report, Building Research Levy, Building Research Association of New Zealand. 183.

Bunker, R., D. Holloway, et al. (2005). "Building the connection between housing needs and metropolitan planning in Sydney, Australia." Housing Studies 20(5): 771-794.

Bunker, R., D. Holloway, et al. (2005). "The expansion of urban consolidation in Sydney: social impacts and implications." Australian Planner: 16-25.

Buxton, M. and G. Tieman (2005). "Patterns of urban consolidation in Melbourne: planning policy and the growth of medium density housing." Urban Policy and Research 23(2): 137-157.

Churchman, A. (1999). "Disentangling the concept of density." Journal of Planning Literature 13(4): 389.

Danielsen, K., R. Lang, et al. (1999). "Retracting suburbia: smart growth and the future of housing." Housing Policy Debate 10(3): 513-540.

Department of Building and Housing (2010). Draft Housing Report.

Dixon, J. and A. Dupuis (2002). "Urban intensification in Auckland, New Zealand: a challenge for new urbanism." Housing Studies 18(3): 353-368.

Duany, A. (2011). "New Urbanism: the case for looking beyond style." Metropolis.

English Partnerships and Housing Corporation (2007). Urban design compendium. London, Llewelyn-Davies.

Farris, J. (2010). The barriers to using urban infill development to achieve smart growth. London, Routledge.

Forster, C. (2006). "The challenge of change: Australian cities and urban planning in the new millennium." Geographical Research 44(2): 173-182.

Gehl, J. (2010). Cities for people. Washington, D.C., Island Press.

Ghosh, D. S. and D. R. Vale (2006). Is policy leading to improved sustainability at the local urban scale? International Conference on Sustainability Engineering and Science (NZSSES) - Talking and Walking Sustainability. Auckland.

Goodchild, B. (1994). "Housing design, urban form and sustainable development: reflections on the future residential landscape." The Town Planning Review 65(2): 143-158.

Hoque, A. (2001). "Urban design intervention for intensive housing." Planning Quarterly(June): 19-22.

Irvine-Smith, F. L. (1948). The streets of my city, Wellington New Zealand. Wellington, A.H & A.W. Reed.

Jabareen, Y. R. (2006). "Sustainable urban forms: their typologies, models, and concepts." Journal of Planning Education and Research: 38-52.

Knack, R. E. (1991). "The one-acre habit is hard to break." Planning 57(8).

Kos, P. (2006). Quantifying the growth spine: supply, demand and capacity for residential development in Wellington City. Wellington Urban Development Strategy. Wellington, Wellington City Council. 9.

Lunday, E. A. (2006). "The power of infiltration." Planning: 16-20.

Lynch, K. (1960). The image of the city. Cambridge, M.I.T. Press.

Michell, A. and D. Wadley (2004). "The process and progress of urban consolidation." Australian Planner: 56-65.

Moos, M. and A. Skaburskis (2008). "The probability of single-family dwelling occupancy: comparing home workers and commuters in Canadian cities." Journal of Planning Education and Research: 319-340.

Murray, S., D. Ramirez-Lovering, et al., Eds. (2008). reHousing: 24 housing projects. Melbourne, RMIT University Press.

Myers, P. (1992). "Seeking the section." Architecture Australia: 22-25.

Peake, S. (2006). How landscape architecture can effect a shift in attitude towards Auckland's suburbs. Auckland, University of Technology. Master by Design.

Phan, T., J. Peterson, et al. (2009). "Residential intensification in a suburban fringe local government area, Casey, Melbourne Metropolitan Area, Australia." Australian Journal of Regional Studies 15(1): 81-100.

Ramirez-Lovering, D. and S. Murray (2011). "DASH - Designing Affordable Sustainable Housing." Architecture Australia: 57-59.

Searle, G. (2003). The limits to urban consolidation. Urban Frontiers Program. Sydney, University of Western Sydney. 14

Smart, E. (1985). Making infill projects work. Washington, Urban Land Institute.

Syme, C., V. McGregor, et al. (2005). Social implications of housing intensification in the Auckland region: analysis and review of media reports, surveys and literature. Urban Form Design and Development. Auckland, Auckland Sustainable Cities Programme.

Thomas, B. (1996). "Repairing the city fabric." Architects' Journal: 42-43.

Tice, J. (1993). "Themes and variations: a typological approach to housing design, teaching and research." Journal of Architectural Education: 162-175.

Untaru, S. (2002). "Regulatory frameworks for place-based planning." Urban Policy and

Research 20(2): 169-186.

Vallance, S., H. C. Perkins, et al. (2005). "The results of making a city more compact: neighbours' interpretation of urban infill." Environment and Planning: 715-733.

Walton, D., S. Murray, et al. (2008). "Relationships between population density and the perceived quality of neighbourhood."

Weidinger, H. (2010). "Low-rise housing typology." Detail: 236-258.

Wellington City Council (2006). Quantifying the growth spine: supply, demand and capacity for residential development in Wellington City. Wellington Urban Development Strategy. Wellington, Wellington City Council. 9.

Wellington City Council (2006). Urban development strategy: directing growth and delivering quality. Wellington, Wellington City Council.

Wellington City Council (2007). Promoting quality of place - a targeted approach to infill housing in Wellington City. Urban Development Strategy. Wellington, Wellington City Council.

Woodcock, I., K. Dovey, et al. (2010). "Modelling the compact city: capacities and visions for Melbourne." Australian Planner 47(2): 94-104.

Wulff, M., E. Healy, et al. (2004). "Why don't small households live in small dwellings? Disentangling a planning dilemma." People and Place 12(1): 57-70.

Further reading

Alexander, C., S. Ishikawa, et al. (1977). A pattern language. New York, Oxford University Press.

Ancell, S. and M. Thompson-Fawcett (2007). "The social sustainability of medium density housing: a conceptual model and Christchurch case study." Housing Studies 23(3): 423-441.

Bunker, R., B. Gleeson, et al. (2002). "The local impacts of urban consolidation in Sydney." Urban Policy and Research 20(2): 143-167.

- Chow, R. (2002). Suburban space: the fabric of dwelling. Berkeley, University of California Press.
- Danielsen, K., R. Lang, et al. (1999). What does smart growth mean for housing? School of Environmental and Public Affairs. Nevada, University of Nevada.
- Davidson, K. (2004). "Us and them - a trans-Tasman comparison of residential building statistics." Retrieved 14 May 2011.
- Day, L. L. (2000). "Choosing a house: the relationship between dwelling type, perception of privacy and residential satisfaction." Journal of Planning Education and Research 19: 265.
- Forsyth, A. and K. Crewe (2009). "A typology of comprehensive designed communities since the Second World War." Landscape Journal 28(1).
- Gregory, R. (2006). "Making a place to dwell; finding a place within the city: how architects are reconfiguring the urban home." The Architectural Review: 36.
- Heiman, R. "The last days of low-density living: suburbs and the end of oil." Built Environment 33(2): 213-226.
- Hermanuz, G., M. Gutman, et al. (1988). Reweaving the urban fabric: approaches to infill housing. New York, New York State Council on the Arts.
- Holloway, A. (2009). "Residential intensification in tramway corridors." Planning News 35(8).
- King, J. (2006). "Building types study 854: Multifamily housing." Architectural Record.
- Landis, J. (2010). The future of infill housing in California: Opportunities, potential, and feasibility. London, Routledge.
- Leusen, M. v. (1996). "A typology of dwelling arrangements." Environment and Planning: 143-164.
- Lorzing, H. "Reinventing suburbia in The Netherlands." Built Environment 32(3): 298-310.
- Lyne, M. and R. Moore (2004). The potential health impacts of residential intensification in Auckland City. School of Population Health School of Applied Sciences. Auckland, University of Auckland, Auckland University of Technology.

Miller, D. C. (2002). "Town planning in New Zealand: the formative years of the discipline." Planning Quarterly: 12-13.

Ministry for the Environment and Urban Design Advisory Group (2005). New Zealand urban design protocol. Wellington, Ministry for the Environment.

Morad, M. and M. Jay "'Freedom's ramparts on the sea': the postcolonial New Zealand landscape and the quest for sustainability." British Review of New Zealand Studies: 119-130.

Moroney, J. and D. Jones (2006). "Biodiversity space in urban environments: implications of changing lot size." Australian Planner 43(4): 22-27.

Norberg-Schulz, C. (1980). Genius loci: towards a phenomenology of architecture. New York, Rizzoli International Publications.

Salmon, K. (1993). "Alternative housing models." Architecture: 85-91.

Salmond, J. (1986). Old New Zealand houses. Auckland, Reed Methuen Publishers Ltd.

176

Schrader, B. (2010). "City planning - early settlement planning." Retrieved 26-07-2011, 2011, from <http://www.TeAra.govt.nz/en/city-planning/1>

Schrader, B. (2010). "City planning - town planning emerges." Retrieved 26-07-2011, 2011, from <http://www.TeAra.govt.nz/en/city-planning/2>

Wellington City Council (2008). Centres policy. Wellington, Wellington City Council.

Appendices

Appendix A

This appendix includes some of the process drawings that led to the planning resolution.

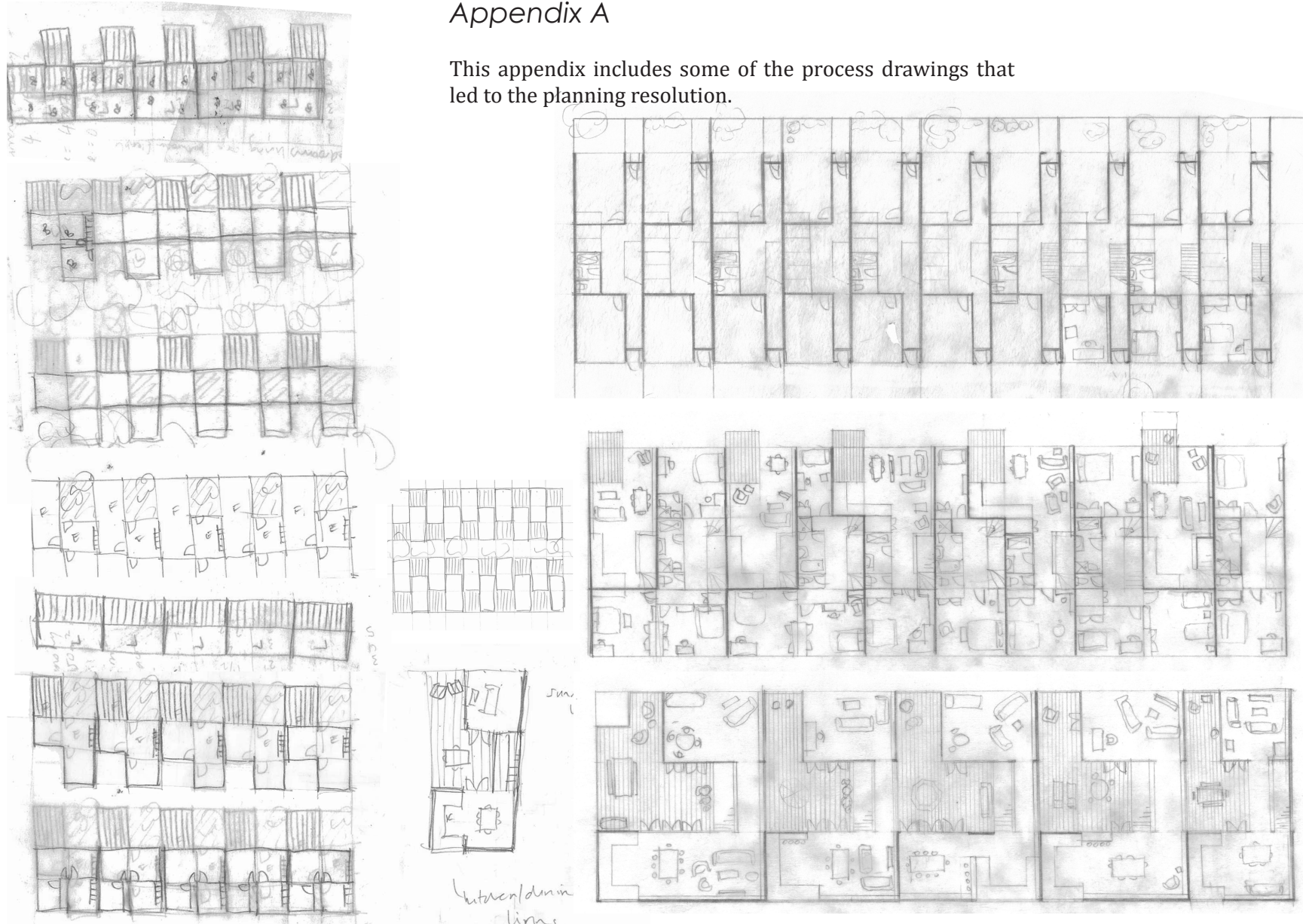

Figure A.1 - North-facing plan development

Source: Authors own image

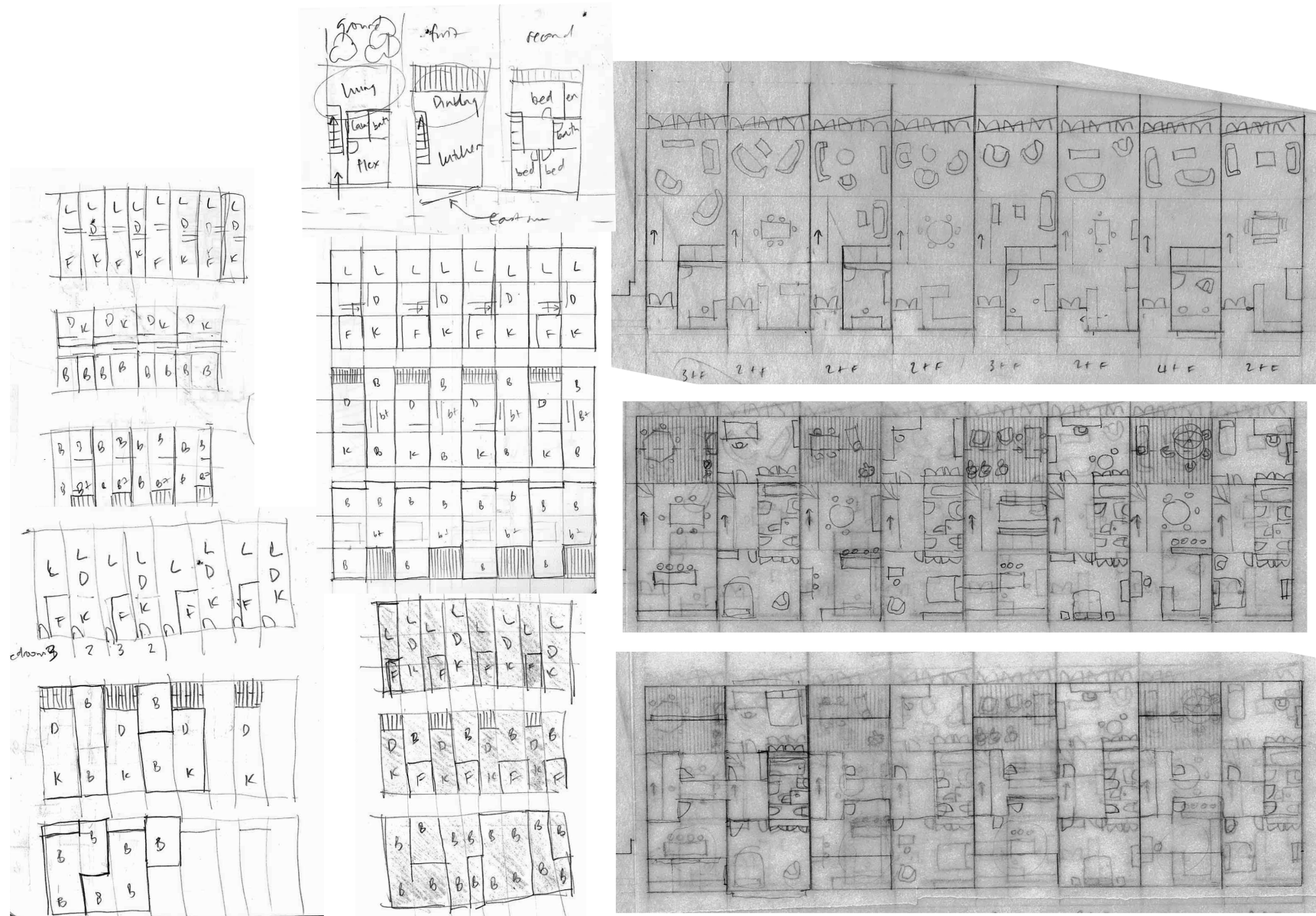

Figure A.2 - South-facing plan development

Source: Authors own image

Appendix B

This appendix includes some of the process drawings that led to the sectional resolution.

182

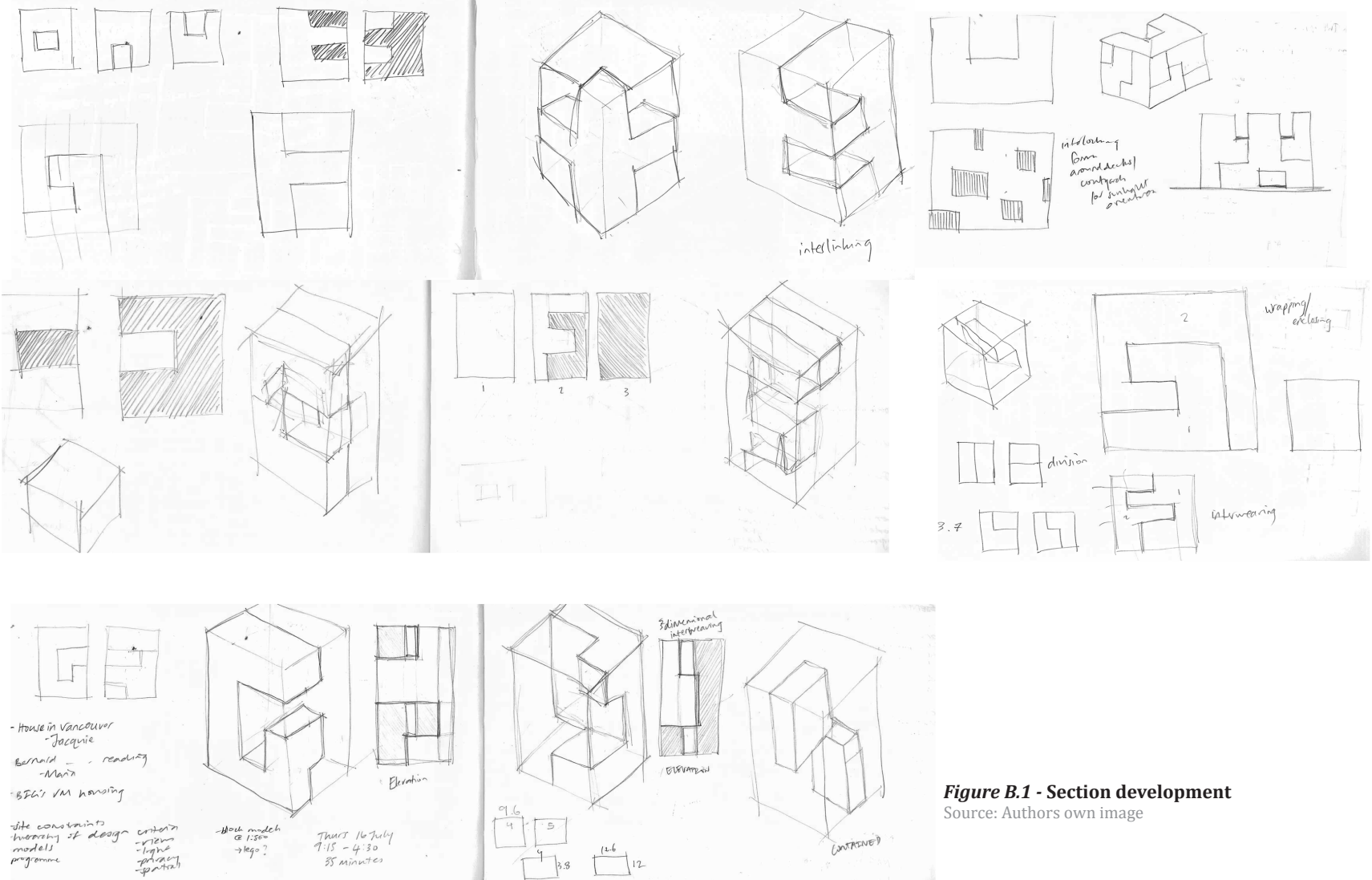

Figure B.1 - Section development
Source: Authors own image

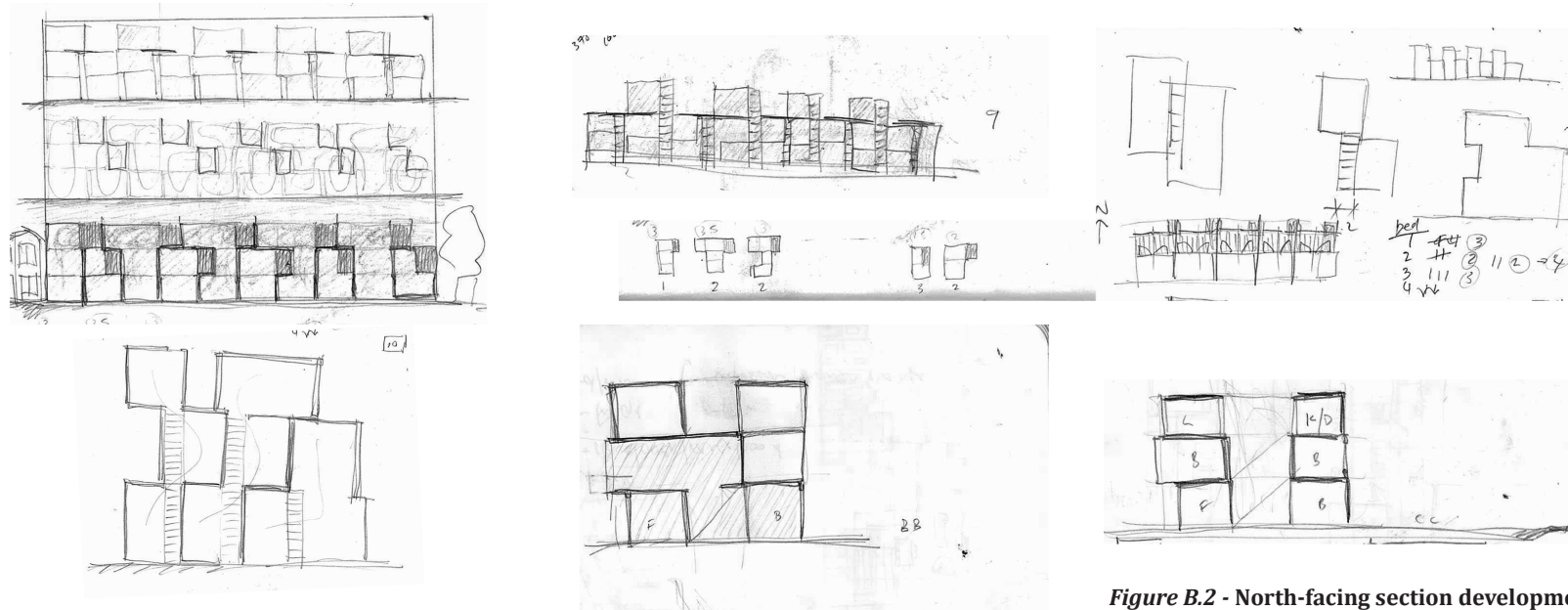

Figure B.2 - North-facing section development
Source: Authors own image

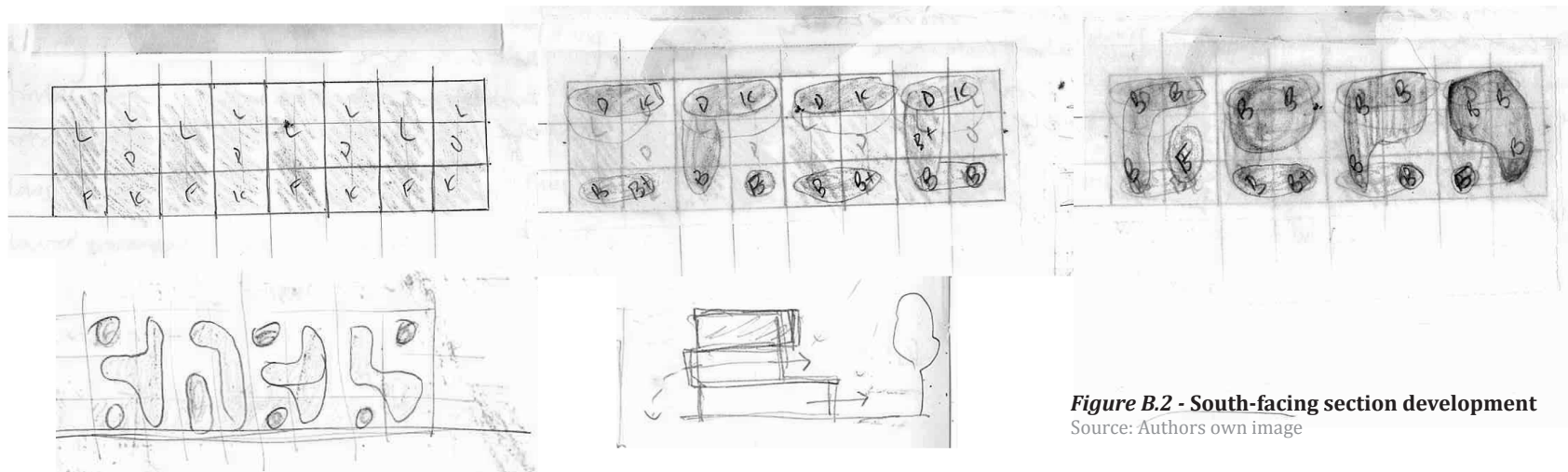

Figure B.2 - South-facing section development
Source: Authors own image

Appendix C

This appendix includes some of the process drawings that led to the elevation resolution.

184

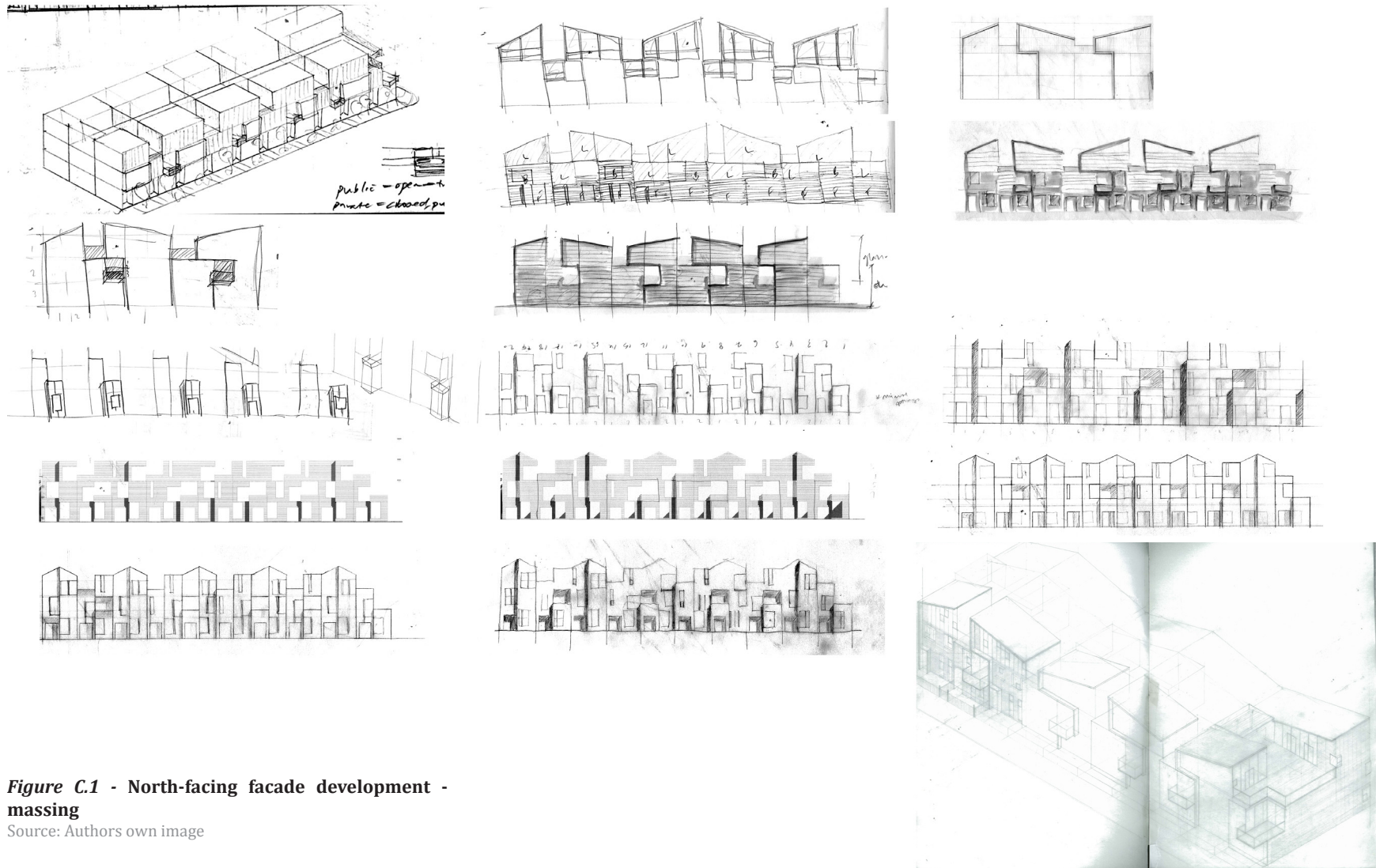

Figure C.1 - North-facing facade development - massing

Source: Authors own image

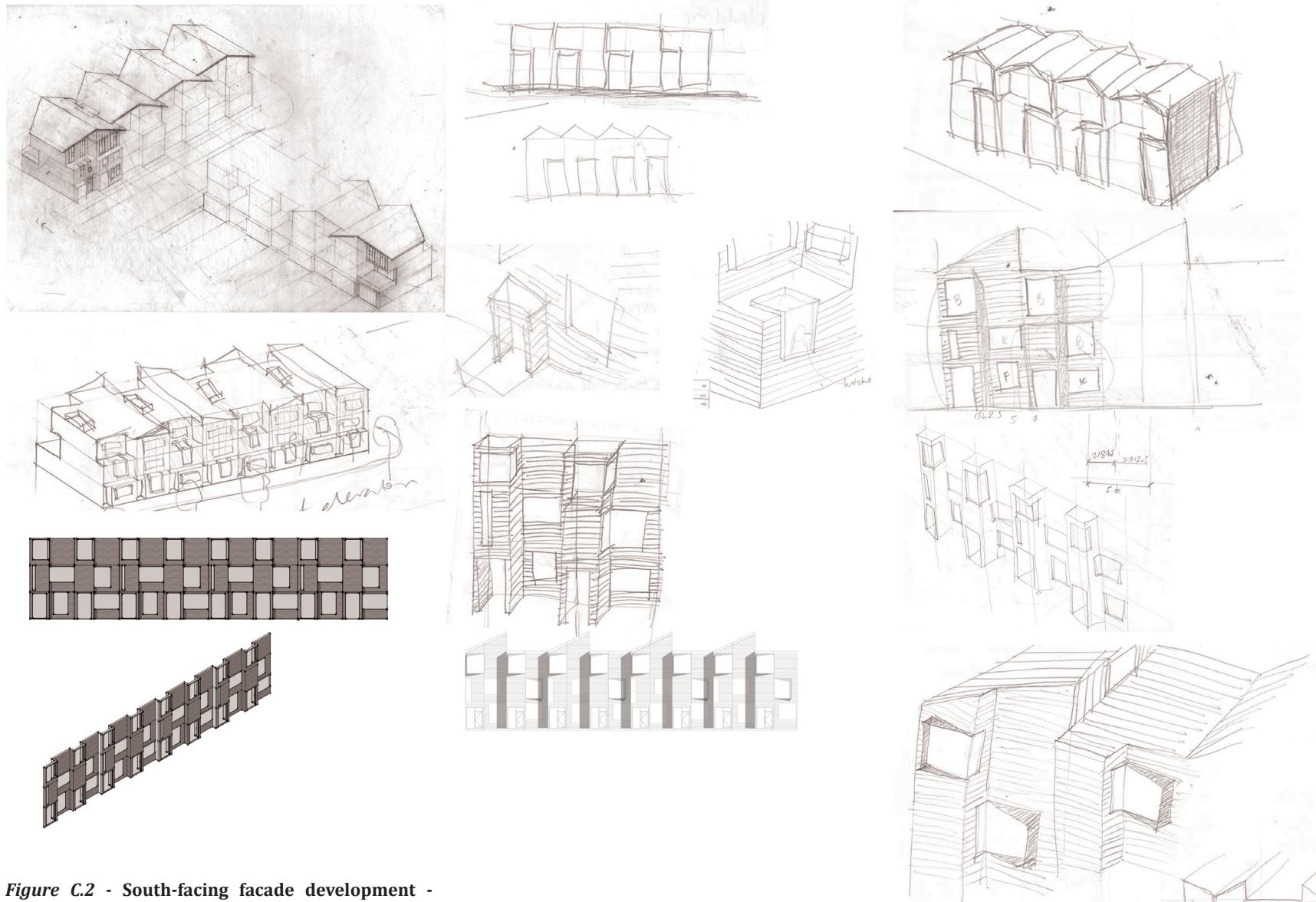
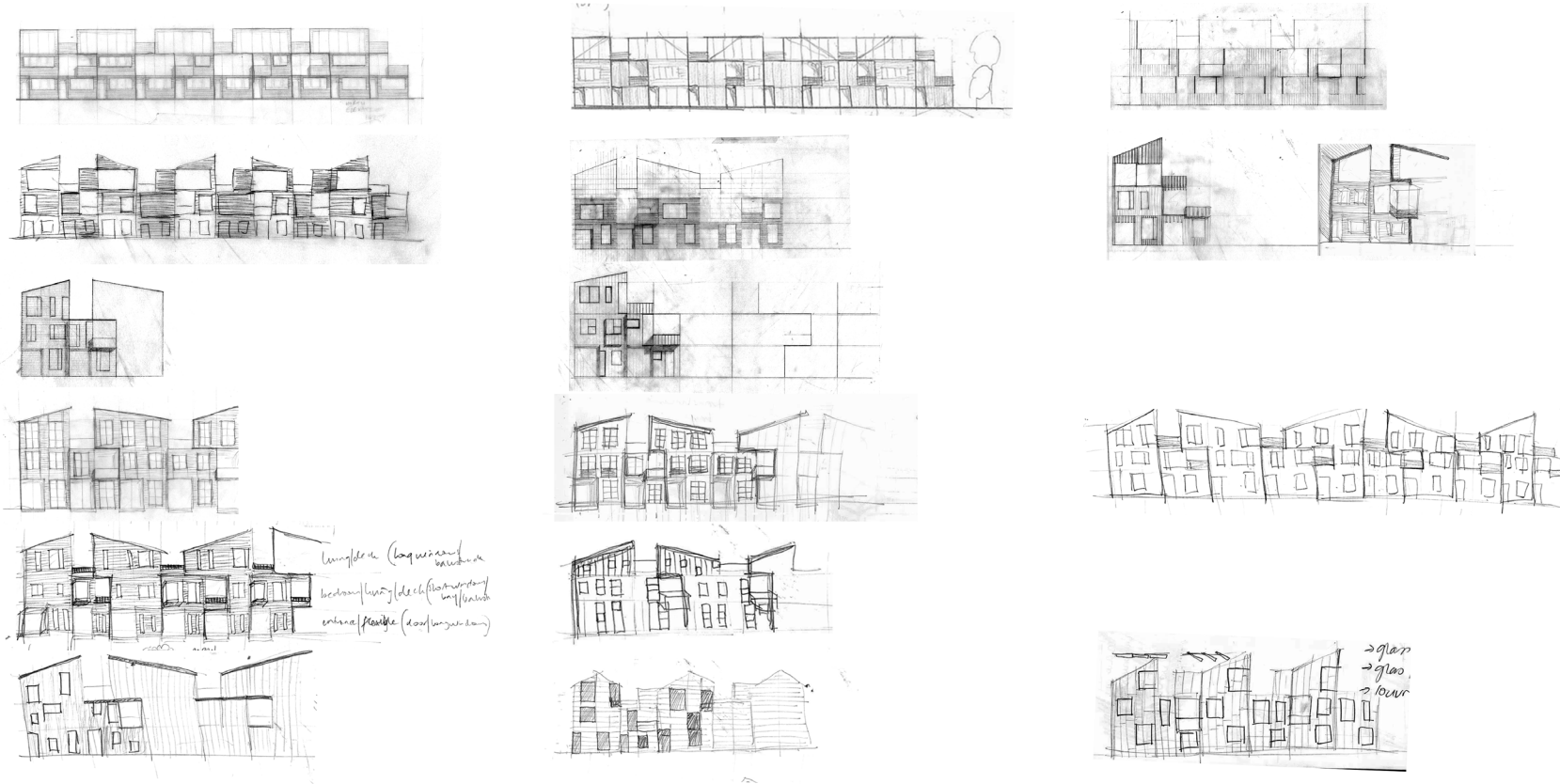

Figure C.2 - South-facing facade development - massing

Source: Authors own image



186

Figure C.3 - North-facing facade development - fenestration

Source: Authors own image

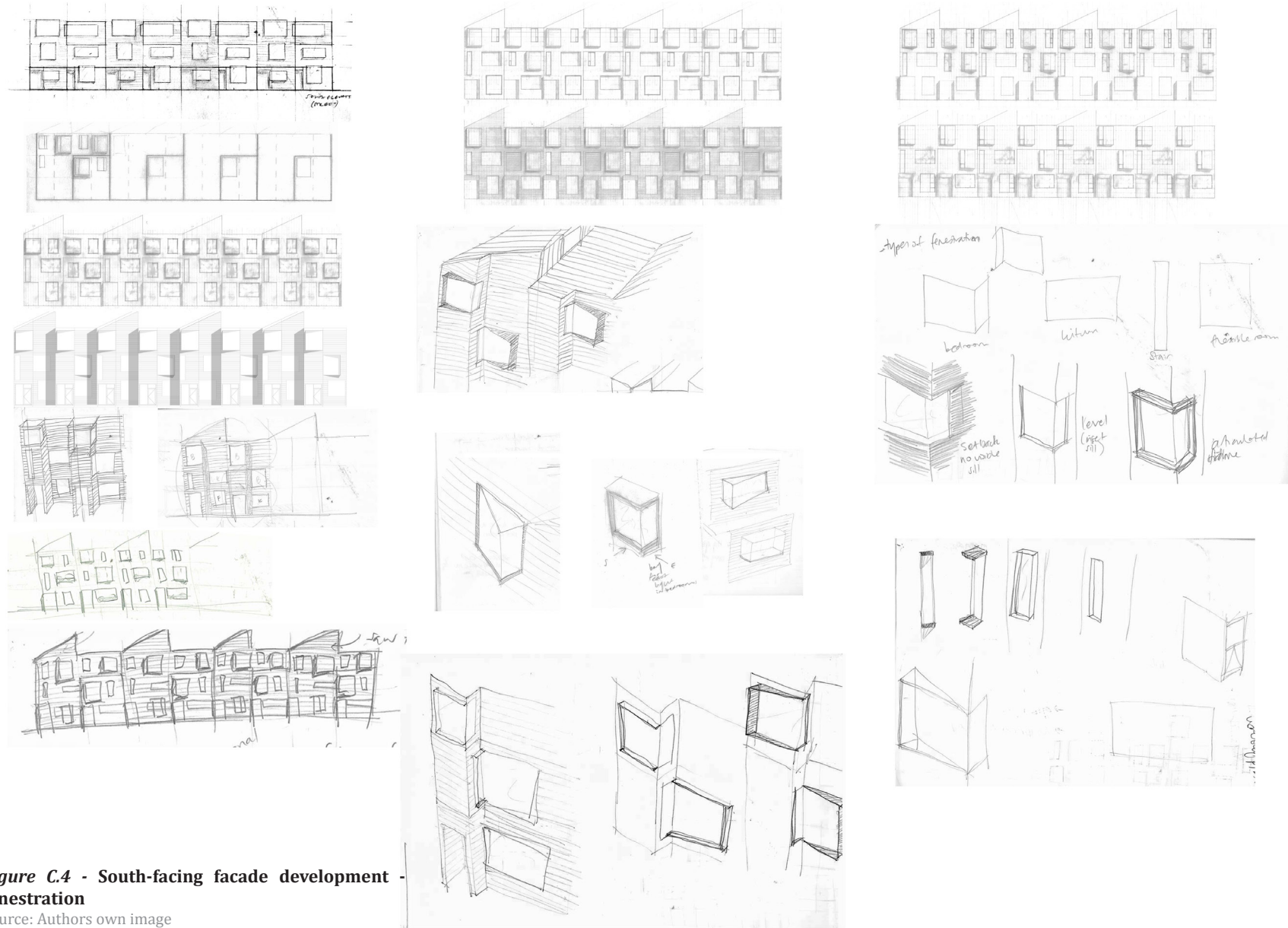

Figure C.4 - South-facing facade development - fenestration

Source: Authors own image

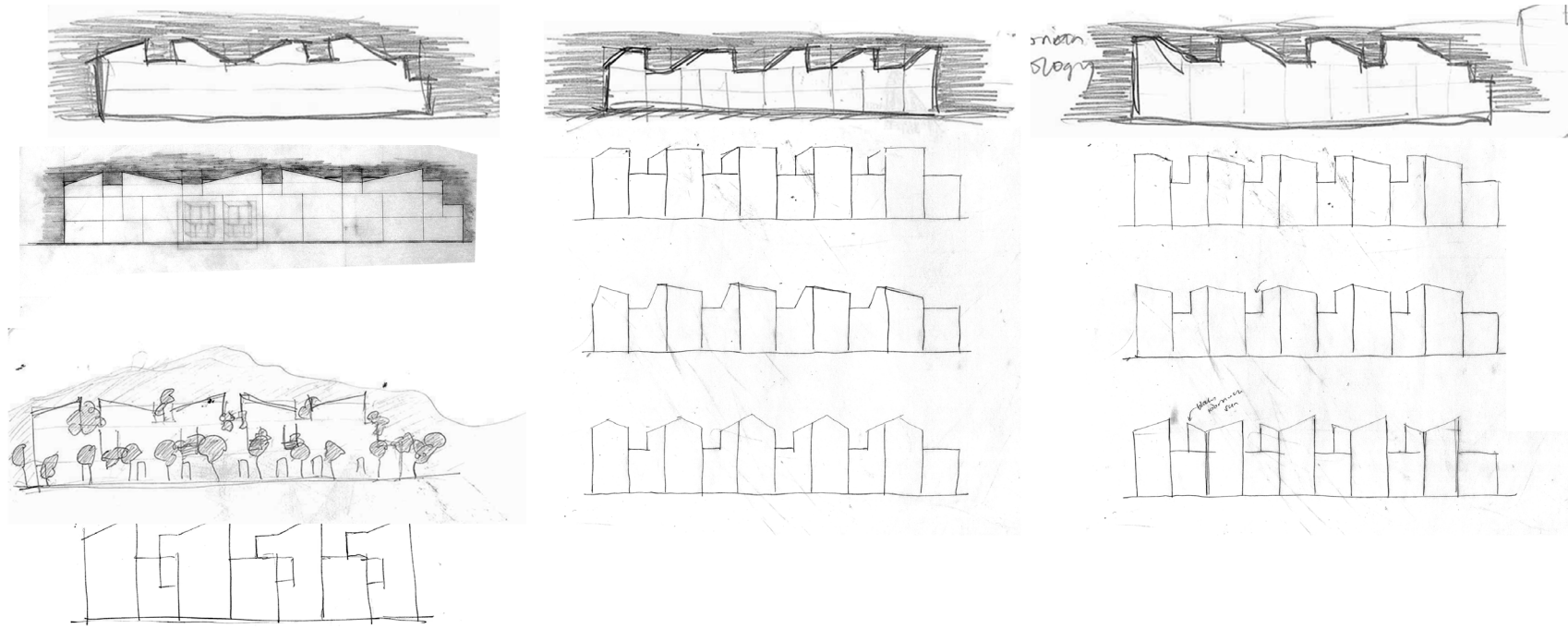
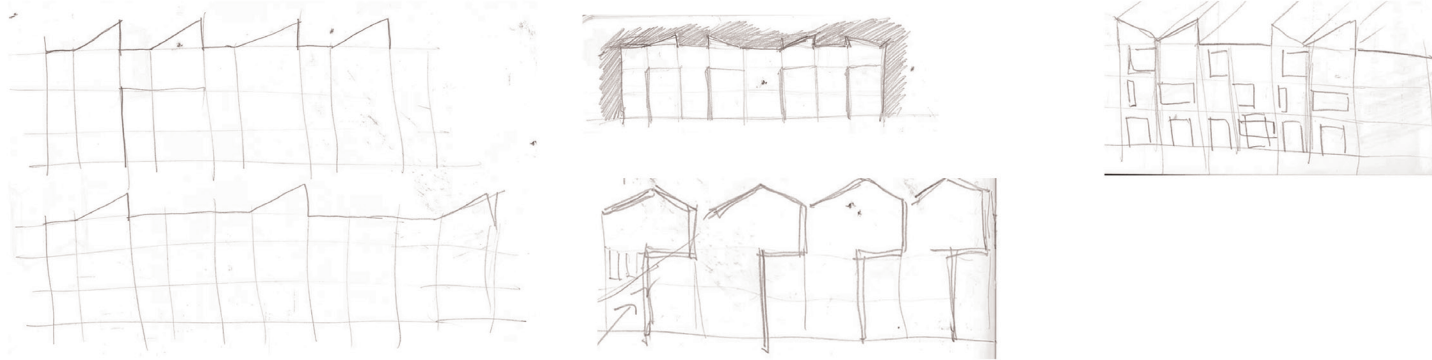

Figure C.5 - North-facing facade development - roofline

Source: Authors own image



**Figure C.6 - South-facing facade development -
roofline**

Source: Authors own image

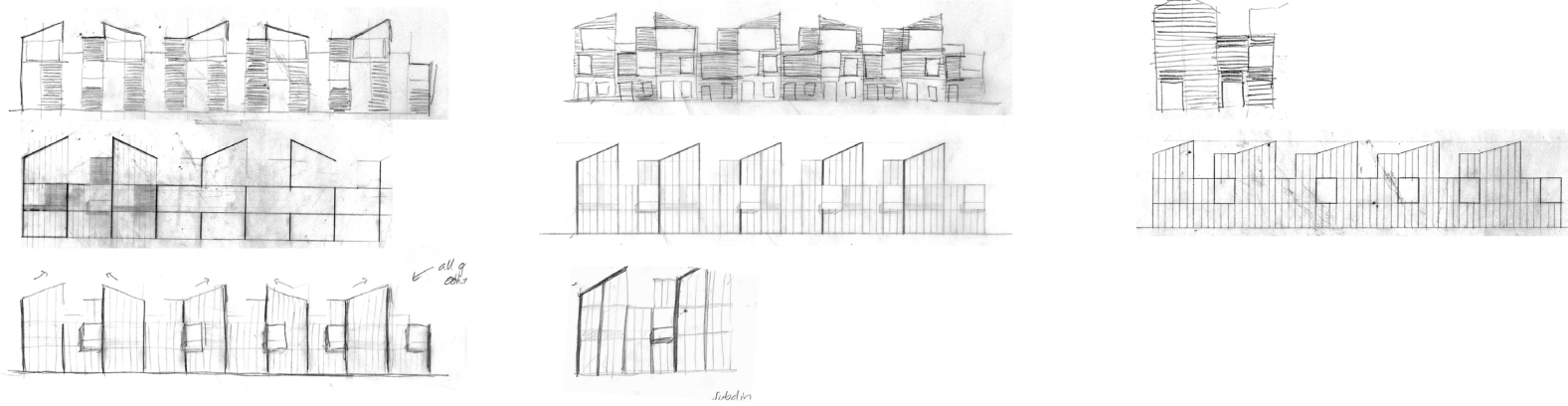

Figure C.7 - North-facing facade development - materials

Source: Authors own image

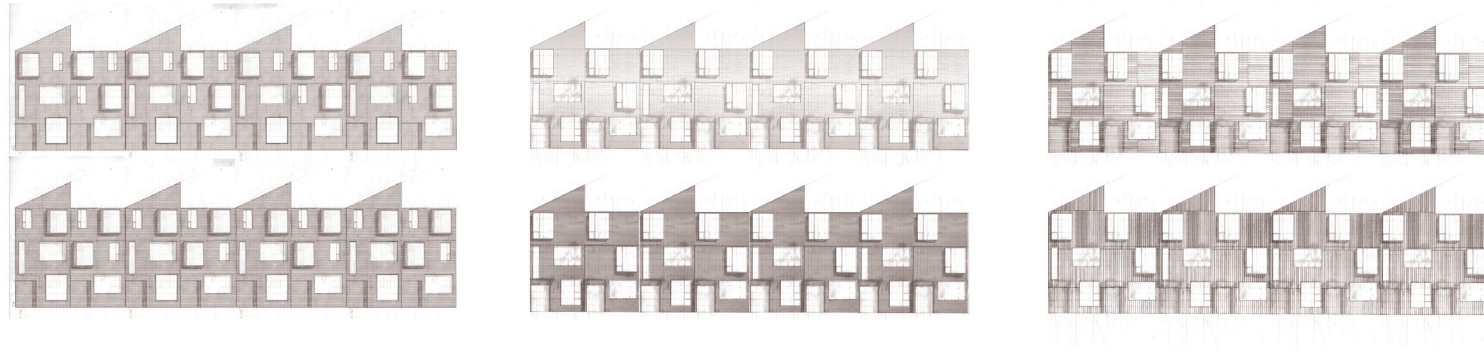

Figure C.8 - South-facing facade development - materials

Source: Authors own image